

Model **DVS**
Manual

Model **DVSA**
Automatic

Model **DVSJ**
Parallel
Alternating

Features

Semi-Vortex impeller

The semi-vortex impeller offers non-clog operation and high pumping efficiency. Allows pumping of waste water containing foreign matter as large as 60~70% of discharge size.

Easy Maintenance

Due to semi-vortex design with no strainer or close tolerance suction cover, only 3 or 4 bolts need to be removed for quick and easy maintenance.

Double mechanical seal in oil chamber

An oil lubricated double mechanical seal with lower faces of hard silicon carbide provides strong and reliable shaft sealing

In built motor protection

Quick acting dual response overloads provides protection against overload, lock or open phase.

Automatic operation

All models up to 3.7 kW are available as automatic (A' type) or parallel alternating (J' type) pumps with inbuilt controls and float switches. No need for separate control panels, simply connect to power source.

Applications

Ideal for waste water applications containing soft or fibrous solids.

Industrial waste water drainage

Septic effluent.

Miscellaneous drainage.

Performance Chart

50Hz

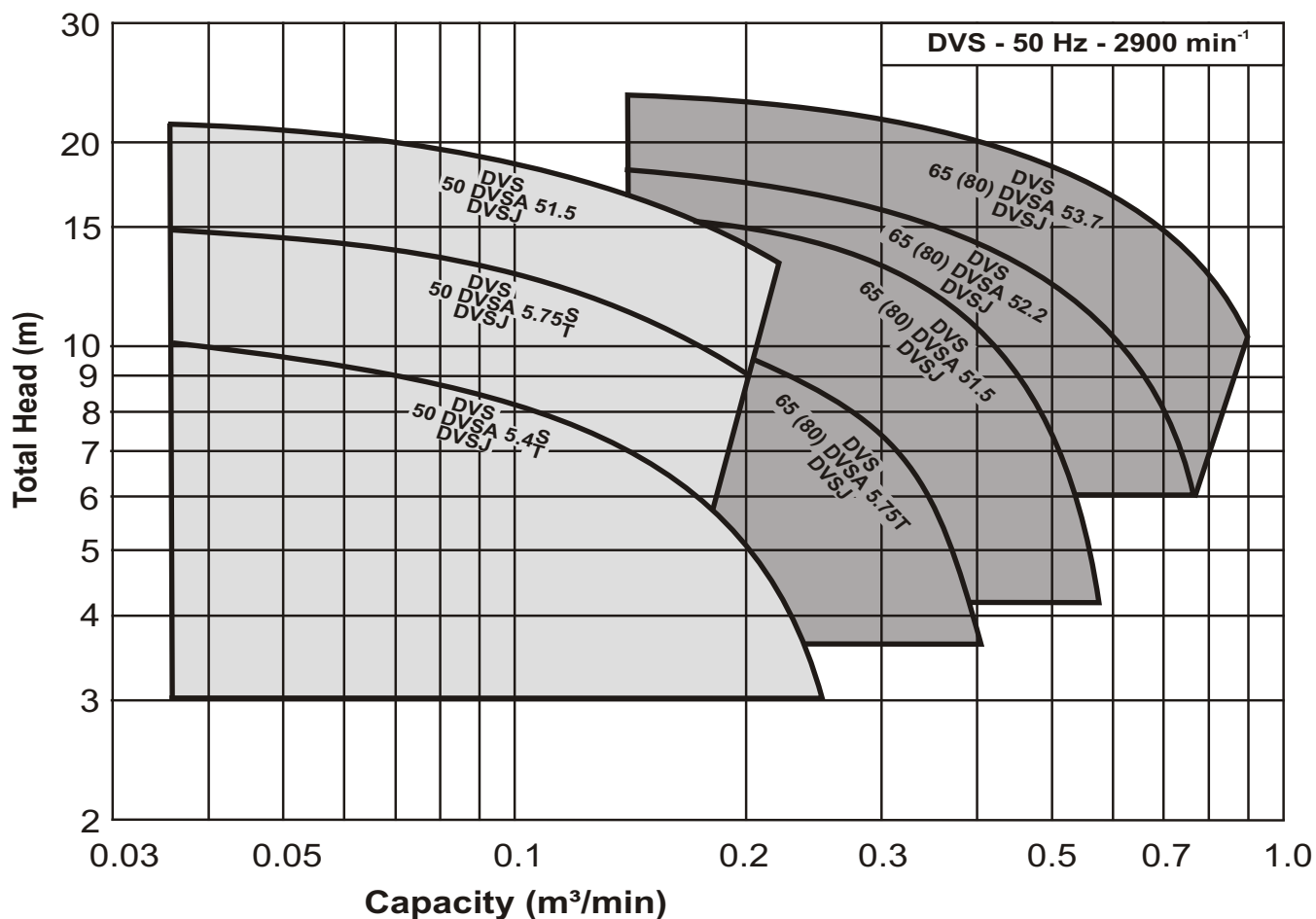

Model code

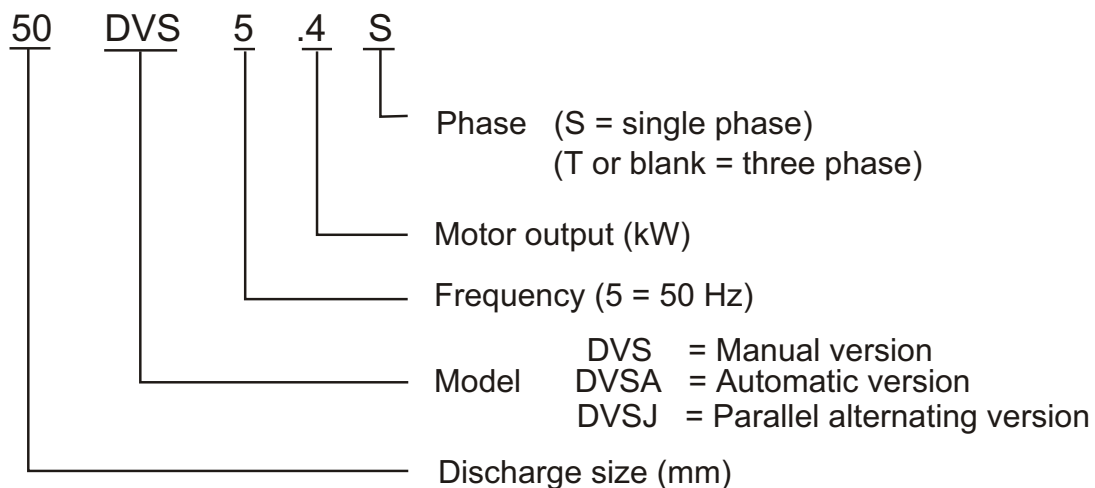

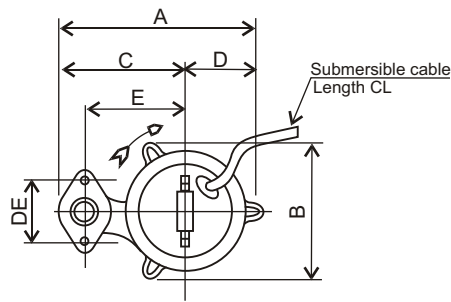

Figure 1

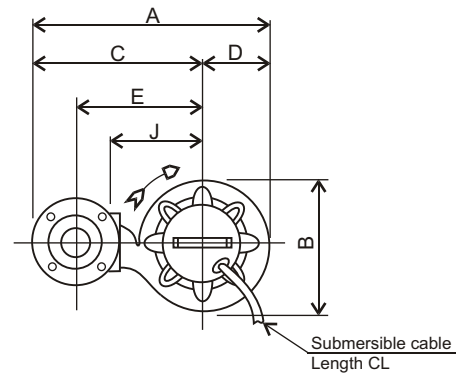
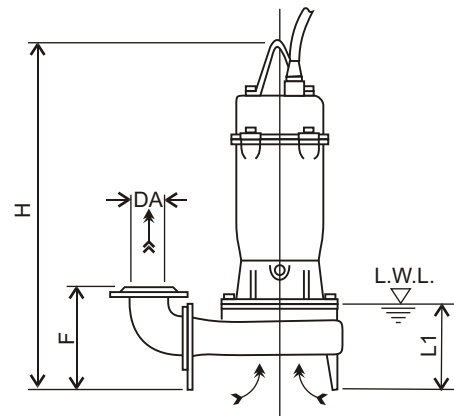
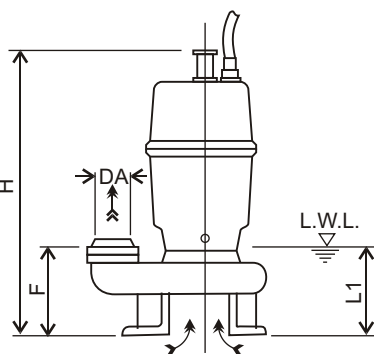

Figure 2



Note:

- 1/. L.W.L (Low Water Level)
Is limited to 10 minutes operation at low water level.
- 2/. Is limited to 30 minutes operation with water level below top of motor.

Discharge Flange Dimensions (JIS 10kgf/cm²)

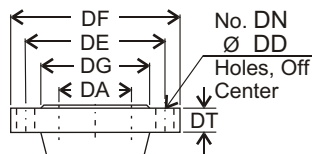

DA	DE	DF	DG	DT	DN	DD
65	140	175	116	18	4	15
80	150	185	126	18	8	15

Size	Model	Fig.	Output KW	Phase	DA	A	B	C	D	E	F	H	DE	J	L1	CL	Weight
50	50 DVS 5.4S	1	0.4	1	PT2"	239	160	148	91	110	82	435	96	-	105	6 m	18 kg
	50 DVS 5.4T	1	0.4	3	PT2"	239	160	148	91	110	82	398	96	-	105	6 m	17 kg
	50 DVS 5.75S	1	0.75	1	PT2"	249	171	163	86	125	82	497	96	-	105	6 m	26 kg
	50 DVS 5.75T	1	0.75	3	PT2"	249	171	163	86	125	82	397	96	-	105	6 m	19 kg
	50 DVS 51.5	1	1.5	3	PT2"	249	171	163	86	125	82	439	96	-	105	6 m	27 kg
65	65 DVS 5.75T	2	0.75	3	65	396	195	298	98	210	178	467	-	145	125	6 m	25 kg
	65 DVS 51.5	2	1.5	3	65	396	195	298	98	210	178	519	-	145	125	6 m	34 kg
	65 DVS 52.2	2	2.2	3	65	427	227	313	114	225	201	643	-	160	155	10m	50 kg
	65 DVS 53.7	2	3.7	3	65	427	227	313	114	225	201	643	-	160	155	10m	59 kg
80	80 DVS 5.75T	2	0.75	3	80	411	195	313	98	220	183	467	-	145	125	6 m	26 kg
	80 DVS 51.5	2	1.5	3	80	411	195	313	98	220	183	519	-	145	125	6 m	35 kg
	80 DVS 52.2	2	2.2	3	80	442	227	328	114	235	206	643	-	160	155	10m	51 kg
	80 DVS 53.7	2	3.7	3	80	442	227	328	114	235	206	643	-	160	155	10m	60 kg

Units: mm unless otherwise specified

Ebara Submersible Semi-vortex Pumps

Model **DVS**

Dimensions with QDC

Pump **DVS** QDC **LS**

Applicable Models - 50 DVS

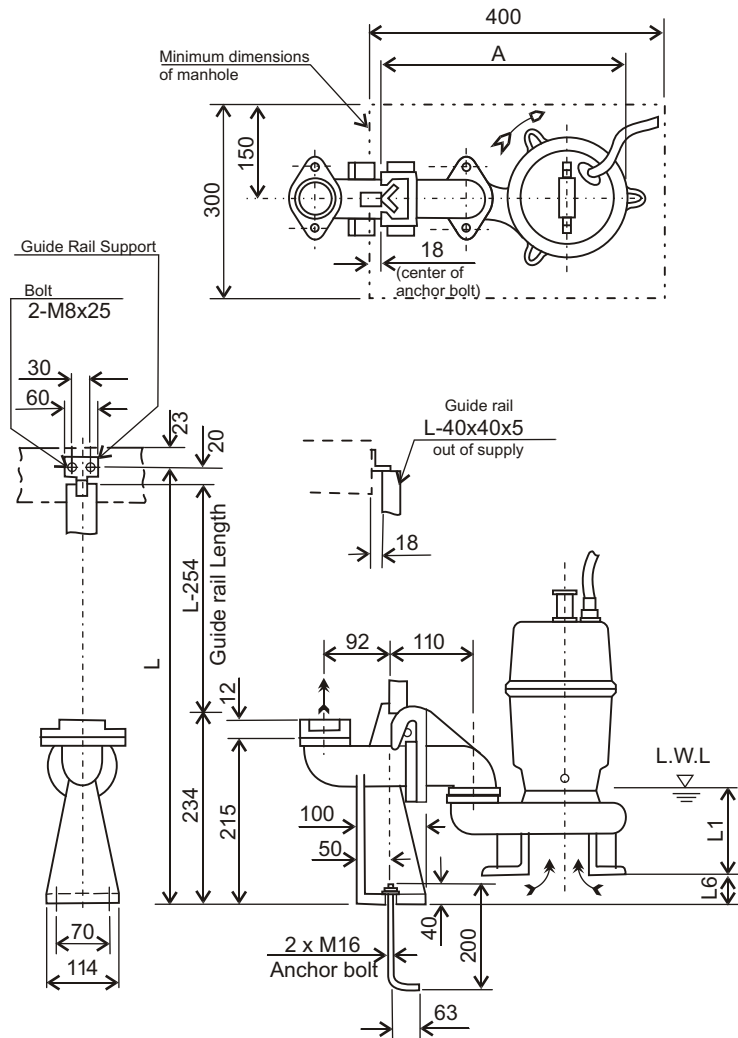

Note:

1/. For detailed dimensions of the pumps, refer to separate dimension data sheets.

2/. The companion flange supplied with the pump are used with the QDC.

3/. The weight in dimension tables refers only to the weight of the QDC.

4/. Standard accessories supplied with QDC include:-

- Connector body with foundation bolts.
- Guide rail support
- Adaptor Flange

Guide Rail is not supplied.

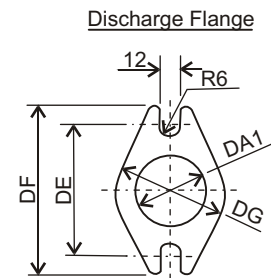

Pump Model	A	DA1	DE	DF	DG	L1	L6	QDC Model	Weight
50 DVS 5.4S	311	50	96	114	76	105	58	LS50	9 kg
50 DVS 5.75S	321	50	96	114	76	105	58	LS50	9 kg
50 DVS 5.4T	311	50	96	114	76	105	58	LS50	9 kg
50 DVS 5.75T	321	50	96	114	76	105	58	LS50	9 kg
50 DVS 51.5	321	50	96	114	76	105	58	LS50	9 kg

Units: mm unless otherwise specified

Ebara Submersible Semi-vortex Pumps

Model **DVS**

Dimensions with QDC

Pump **DVS** QDC **LM**

■ Applicable Models - 65 & 80 DVS

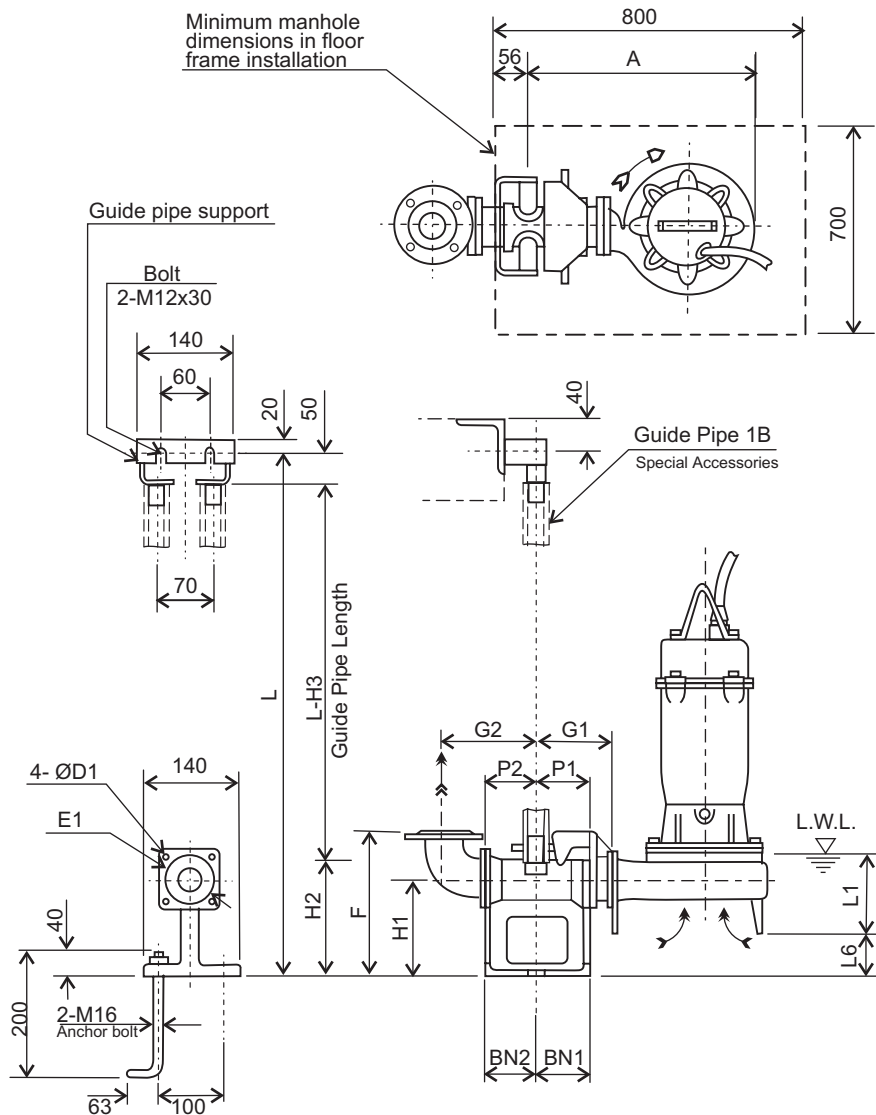

Note:

1/ For detailed dimensions of the pumps, refer to separate dimension data sheets.

2/ The discharge bend and companion flange supplied with the pump are used with the QDC.

3/ The weight in dimension tables refers only to the weight of the QDC.

4/ Standard accessories supplied with QDC include:-

- Connector body with foundation bolts.
- Guide pipe support
- Sliding Glide
- Adaptor Flange

Guide Pipe is not supplied.

Discharge Flange
(JIS 10kgf/cm²)

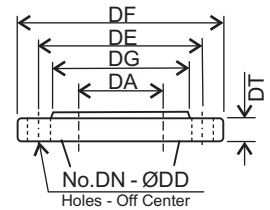

DA	DE	DF	DG	DT	DN	DD
65	140	175	116	18	4	15
80	150	185	126	18	8	15

Pump Model	A	P1	P2	G1	G2	F	H1	H2	H3	L1	L6	BN1	BN2	D1	E1	QDC Model	Weight
65 DVS 5.75T	363	75	95	120	160	250	145	190	240	125	72	75	95	12	140	LM65	14 kg
65 DVS 51.5	363	75	95	120	160	250	145	190	240	125	72	75	95	12	140	LM65	14 kg
65 DVS 52.2	394	75	95	120	160	250	145	190	240	155	49	75	95	12	140	LM65	14 kg
65 DVS 53.7	394	75	95	120	160	250	145	190	240	155	49	75	95	12	140	LM65	14 kg
80 DVS 5.75T	363	75	95	120	170	255	145	190	240	125	72	75	95	12	140	LM65	14 kg
80 DVS 51.5	363	75	95	120	170	255	145	190	240	125	72	75	95	12	140	LM65	14 kg
80 DVS 52.2	394	75	95	120	170	255	145	190	240	155	49	75	95	12	140	LM65	14 kg
80 DVS 53.7	394	75	95	120	170	255	145	190	240	155	49	75	95	12	140	LM65	14 kg

Units: mm unless otherwise specified