

Model DF
Manual



Model DFA
Automatic

Features

Non-clog operation with “cutting” action

Non-clog semi-open impeller and “cutting” action prevents clogging by fibrous matter. Models up to 3.7 kW have a chrysalis shaped suction port, while larger models have a radially grooved suction cover.

Robust construction

Rugged cast iron construction, all fasteners of stainless steel and a 4 pole motor.

Double mechanical seal in oil chamber

An oil lubricated double mechanical seal with lower faces of hard silicon carbide provides strong and reliable shaft sealing

In built motor protection

Quick acting dual response overloads provides protection against overload, lock or open phase.

Automatic operation

All models up to 3.7 kW are available as automatic (A' type) pumps with inbuilt controls and float switches. No need for separate control panels, simply connect to power source.

Applications

Sewage
Waste water
Storm water drainage

Performance Chart

50Hz

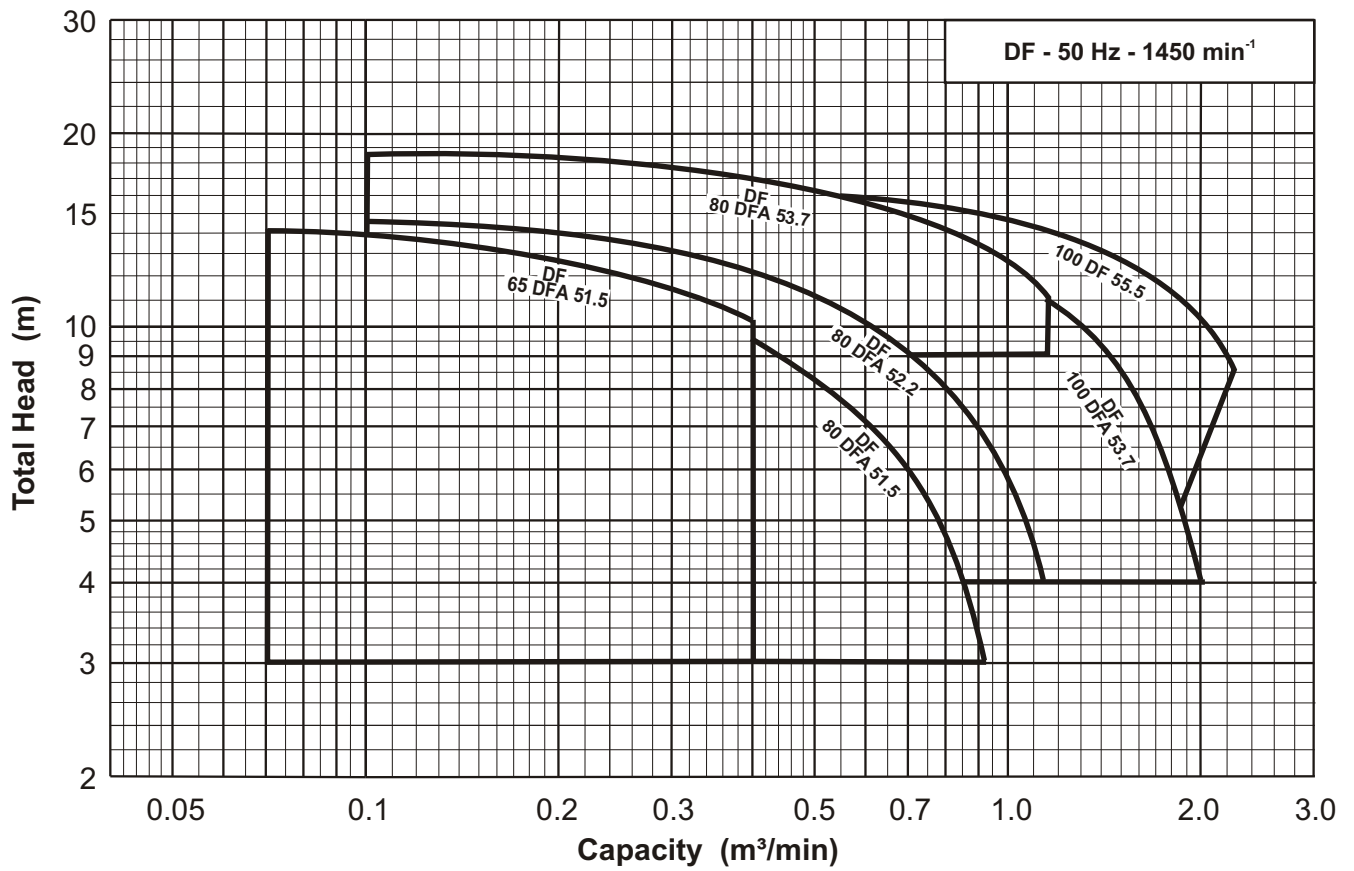

Model code

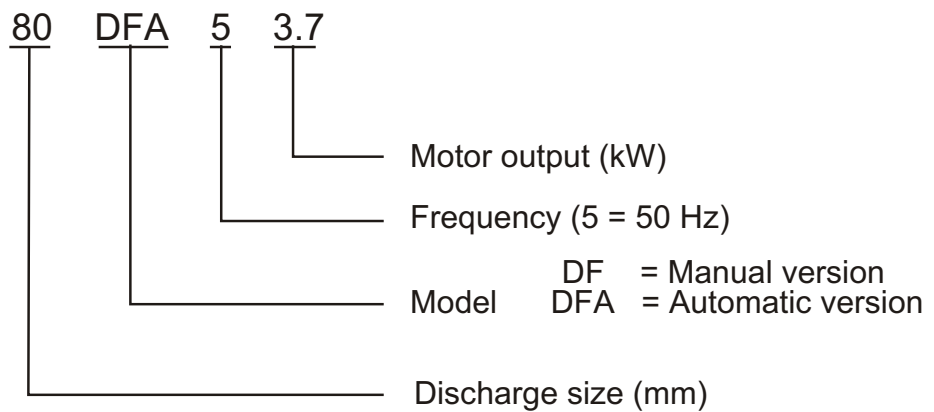

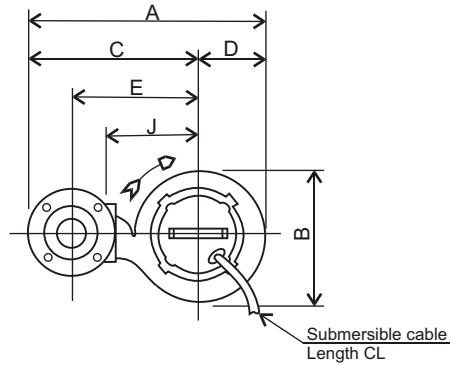

Discharge Flange Dimensions
(JIS 10kgf/cm²)

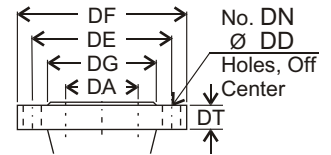

DA	DE	DF	DG	DT	DN	DD
65	150	175	116	18	4	15
80	150	185	126	18	4	15
100	175	210	151	20	8	15

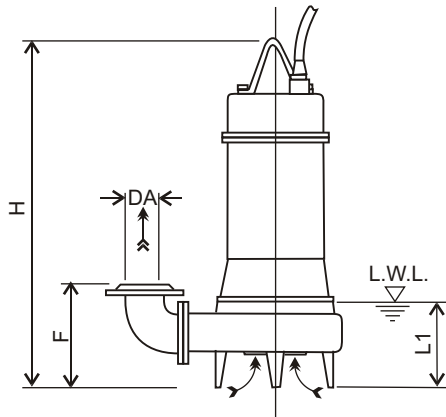

Note:

- 1/. L.W.L. (Low Water Level)
Is limited to 10 minutes operation at low water level.
- 2/. Is limited to 30 minutes operation with water level below top of motor.

Size DA	Model	Output KW	A	B	C	D	E	F	H	J	L1	CL	Weight
65	65 DF 51.5	1.5	497	291	353	144	265	200	576	200	140	10 m	52 kg
80	80 DF 51.5	1.5	524	292	378	146	285	220	597	210	165	10 m	55 kg
	80 DF 52.2	2.2	542	308	388	154	295	220	654	220	165	10 m	67 kg
	80 DF 53.7	3.7	567	328	403	164	310	220	687	235	165	10 m	75 kg
100	100 DF 53.7	3.7	614	335	445	169	340	250	706	235	185	10 m	79 kg
	100 DF 55.5	5.5	646	369	460	186	355	323	768	250	205	10 m	123 kg

Units: mm unless otherwise specified

Ebara Submersible Sewage Pumps (With Cutter)

Model **DF**

Dimensions with QDC

Pump **DF** QDC **LM**

Applicable Models - 65 & 80 DF

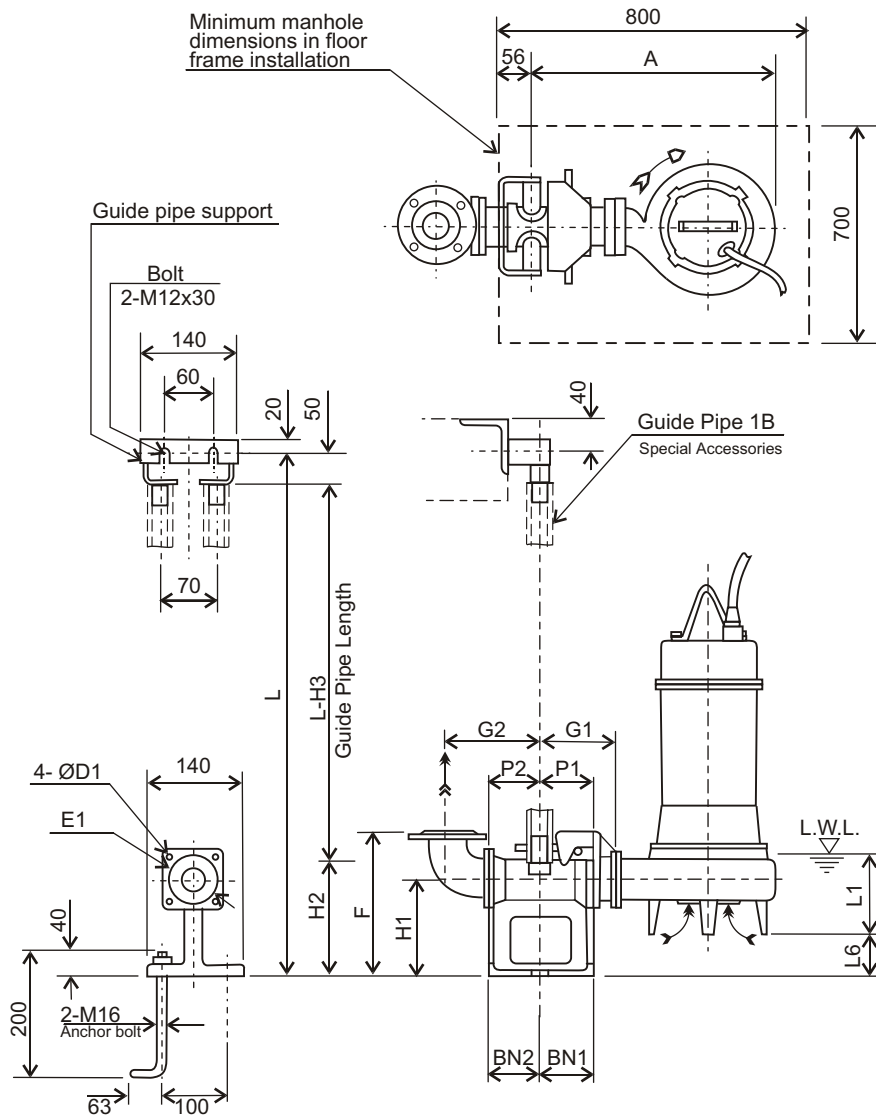

Note:

1/. For detailed dimensions of the pumps, refer to separate dimension data sheets.

2/. The discharge bend and companion flange supplied with the pump are used with the QDC.

3/. The weight in dimension tables refers only to the weight of the QDC.

4/. Standard accessories supplied with QDC include:-

- Connector body with foundation bolts.
- Guide pipe support
- Sliding Glide
- Adaptor Flange

Guide Pipe is not supplied.

Discharge Flange
(JIS 10kgf/cm²)

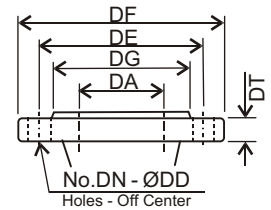

DA	DE	DF	DG	DT	DN	DD
65	140	175	116	18	4	15
80	150	185	126	18	8	15

Pump Model	A	P1	P2	G1	G2	F	H1	H2	H3	L1	L6	BN1	BN2	D1	E1	QDC Model	Weight
65 DF 51.5	464	75	95	120	160	250	145	190	240	140	50	75	95	12	140	LM65	14 kg
80 DF 51.5	481	75	90	125	165	285	175	230	280	165	65	75	90	15	155	LM80	17 kg
80 DF 52.2	499	75	90	125	165	285	175	230	280	165	65	75	90	15	155	LM80	17 kg
80 DF 53.7	524	75	90	125	165	285	175	230	280	165	65	75	90	15	155	LM80	17 kg

Units: mm unless otherwise specified

Applicable Models - 100 DF

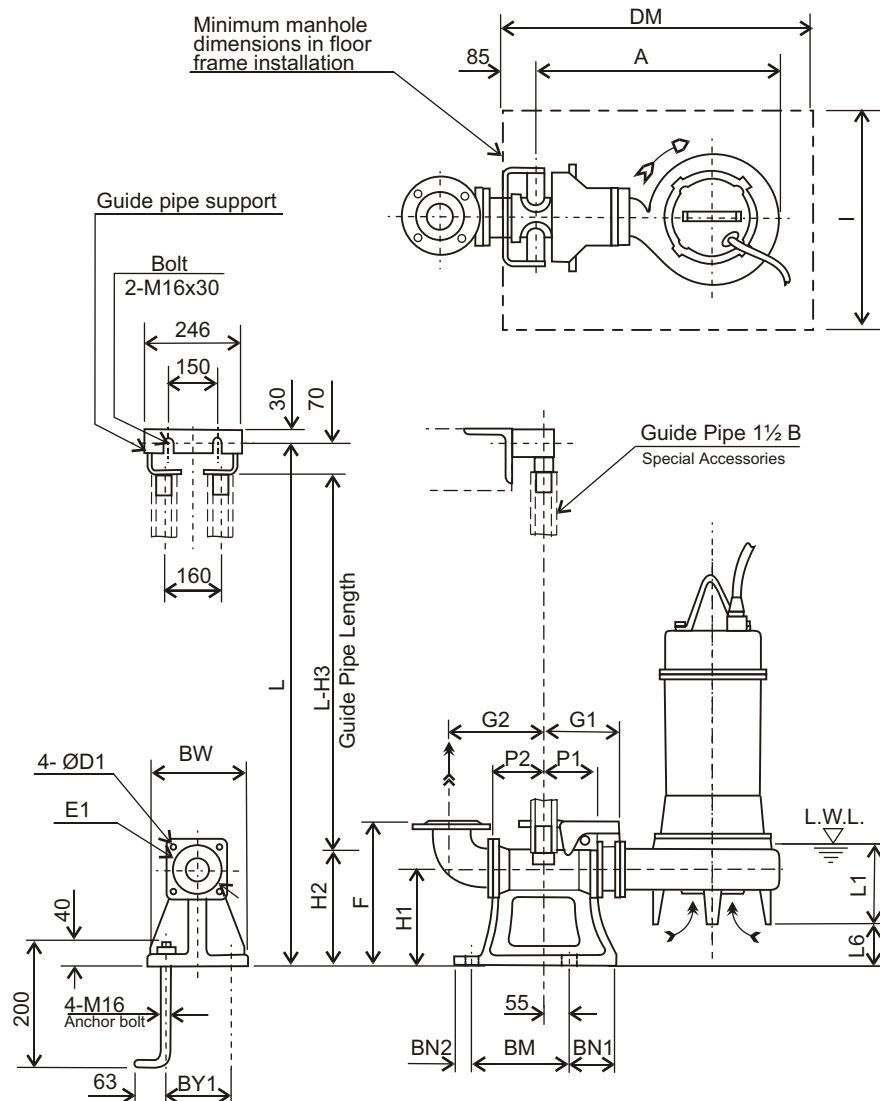

Note:

1/. For detailed dimensions of the pumps, refer to separate dimension data sheets.

2/. The discharge bend and companion flange supplied with the pump are used with the QDC.

3/. The weight in dimension tables refers only to the weight of the QDC.

4/. Standard accessories supplied with QDC include:-

- Connector body with foundation bolts.
- Guide pipe support
- Sliding Glide
- Adaptor Flange

Guide Pipe is not supplied.

Discharge Flange
(JIS 10kgf/cm²)

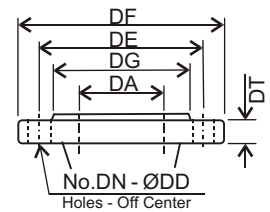

DA	DE	DF	DG	DT	DN	DD
100	175	210	151	20	8	15

Pump Model	A	P1	P2	G1	G2	F	H1	H2	H3	L1	L6	BN1	BN2	BM	BY1	BW	DM	I	D1	E1	QDC Model	Weight
100 DF 53.7	589	105	105	185	210	365	240	265	335	185	115	100	40	220	180	230	800	700	19	175	LL100	46 kg
100 DF 55.5	621	105	105	185	210	365	240	265	335	205	42	100	40	220	180	230	800	700	19	175	LL100	46 kg
100 DF 57.5	648	105	105	185	210	365	240	265	335	205	42	100	40	220	180	230	800	700	19	175	LL100	46 kg

Units: mm unless otherwise specified