



DUMPER

Data Book 50 Hz

	Page
- SPECIFICATIONS	200
SELECTION CHART	201
TYPE KEY AND CURVE SPECIFICATIONS	202
CURVE SPECIFICATIONS	203
PERFORMANCE CURVE DUMPER 1X 51-S	204
PERFORMANCE CURVE DUMPER 1X 51.5-S	205
PERFORMANCE CURVE DUMPER 2X 51.5-S	206
PERFORMANCE CURVE DUMPER 2X 52.2-S	207
PERFORMANCE CURVE DUMPER 2X 53-S	208
PERFORMANCE CURVE DUMPER 3X 53.7-S	209
PERFORMANCE CURVE DUMPER 3X 53.7-M	210
PERFORMANCE CURVE DUMPER 3X 53.7-L	211
PERFORMANCE CURVE DUMPER 3X 55.5-S	212
PERFORMANCE CURVE DUMPER 3X 55.5-M	213
PERFORMANCE CURVE DUMPER 3X 57.5-S	214
PERFORMANCE CURVE DUMPER 3X 57.5-M	215
PERFORMANCE CURVE DUMPER 4X 512-S	216
PERFORMANCE CURVE DUMPER 4X 512-M	217
PERFORMANCE CURVE DUMPER 5X 58-S	218
PERFORMANCE CURVE DUMPER 6X 519-S	219
PERFORMANCE CURVE DUMPER 6X 519-M	220
PERFORMANCE CURVE DUMPER 6X 526-S	221
PERFORMANCE CURVE DUMPER 6X 526-M	222
PERFORMANCE CURVE DUMPER 70 537-S	223
PERFORMANCE CURVE DUMPER 60 537-M	224
- CONSTRUCTIONS	300
SECTIONAL VIEW DUMPER 1X, 2X, 3X, 4X, 6X, 7X	300
SECTIONAL VIEW TABLE DUMPER 1X, 2X, 3X, 4X, 6X, 7X	301
SECTIONAL VIEW DUMPER 3X 5(3.7, 5.5, 7.5)-S T	302
SECTIONAL VIEW TABLE DUMPER 3X 5(3.7, 5.5, 7.5)-S T	303
SECTIONAL VIEW DUMPER 5X 58-S	304
SECTIONAL VIEW TABLE DUMPER 5X 58-S	305
MECHANICAL SEAL	306
BEARINGS	307
- DIMENSIONS AND WEIGHT	400
PUMP DUMPER 1X, 2X SERIES	400
PUMP DUMPER 3X, 4X, 5X, 6X, 7X SERIES	401
PACKING	402
- TECHNICAL DATA	500

SPECIFICATION

50Hz

Rev. 0

PUMP	Type of liquid	Clear water			
	Max Temp.	[°C]	40°		
	Liquid Handled	Max solids size	[mm]	25x6 DUMPER 3X 53.7(L,M) 30x9.5 DUMPER 3X 5(5.5, 7.5)-M 25.5x5 DUMPER 4X 512-M) 25.5x10 DUMPER 6X 5(19,26,37)-M Ø 6 DUMPER 1X, 2X, 3X 5(3.7,5.5,7.5)-S, 5X Ø 10 DUMPER 4X 512-S, DUMPER 6X 5(19, 26)-S Ø 13 DUMPER 7X	
	Submergence	Max	[m]	15	
		Min	[m]	0.127	
	Construction	Impeller	Open		
		Shaft seal type	Double mechanical seal wholly enclosed in a pressure compensated oil chamber		
	Connection	Suction	Strainer		
		Discharge	Hose (standard)	[mm]	50 DUMPER 1X, 2X 51.5-S 75 DUMPER 2X 5(2.2,3)-S, 3X-S, DUMPER 5X 100 DUMPER 3X-(L,M), 4X 512-S, 6X 519-S 150 DUMPER 4X 512-M, 6X 519-M, 6X 526-S, 7X 200 DUMPER 6X 526-M, 6X 537-M
			Threaded (Optional)	[inch]	2 DUMPER 1X, 2X 51.5 3 DUMPER 3X-S, 2X 5(2.2,3)-S, 5X 4 DUMPER 3X-(L,M), 4X 512-S, 6X 519-S 6 DUMPER 4X 512-M, 6X 519-M, 6X 526-S, 7X 8 DUMPER 6X 526-M, DUMPER 6X 537-M
Materials		Casing	Aluminium (up to 8 kW) Steel (from 12 kW and higher)		
	Impeller	Nitride hardened Aisi 410			
	Suction Cover	Aisi 304			
	Shaft	Aisi 431			
	Fasteners	Aisi 304			
	Mechanical seal	Tungsten Carbide/ Tungsten Carbide /NBR (Motor side) Tungsten Carbide/ Tungsten Carbide /NBR (Impeller Side)			
Applicable standard of test		ISO 9906 Annex A			
MOTOR	Type	Induction, continuous rated, motor with squirrel cage rotor			
		Single Phase	Three Phase		
	No. of Poles	2			
	Rotation speed	[min ⁻¹]	2800		
	Insulation Class	H			
	Protection degree	IP 68			
	Power Rating	[kW]	1 ÷ 2.2	1 ÷ 37	
		[HP]	1.3 ÷ 3	1.3 ÷ 50	
	Frequency	[Hz]	50		
	Voltage	[V]	230 ±6%	400 ±6%	
	Starting	up to 8 kW	DOL		
		12 kW and above	/	Y/Δ DOL (optional)	
	Over load protection	DUMPER 1X 51-S M	Built-in motor protector with automatic reset		
		DUMPER 5X 58-S T	Built in thermal probe and contactor with automatic reset		
		The other	Built in thermal probe - Protection must be provided by the user		
Cable	material	H07RN-F			
	length	[m]	20		
	stainless steel sheath	[m]	1 (pump side)		
Bearings	up to 7.5 kW	Two single row, deep groove ball bearing			
	8 kW and above	Single row, deep groove (upper bearing) Double angular contact (lower bearings)			

DEWATERING PUMPS

DUMPER

SELECTION CHART

50Hz

Rev. 0

Model (*)		P ₂		Capacity													
Single Phase	Three Phase	kW	HP	l/min	50	100	150	200	250	300	350	400	450	480	550	600	650
				m ³ /h	3	6	9	12	15	18	21	24	27	28.8	33	36	39
				Head in m													
DUMPER 10 51-S M(-NC)	DUMPER 1X 51-S T	1	1.3	16.0	15.1	14.1	12.8	11.5	10.2	8.7	6.9	4.8	2.0	0	-	-	-
-	DUMPER 1X 51.5-S T	1.5	2	16.0	15.7	15.2	14.6	13.8	12.9	11.8	10.6	9.3	7.8	6.8	4.2	2.2	0

Model (*)		P ₂		Capacity													
Single Phase	Three Phase	kW	HP	l/min	200	300	400	500	600	700	800	900	1000	1100	1200	1270	1400
				m ³ /h	12	18	24	30	36	42	48	54	60	66	72	76.2	84
				Head in m													
DUMPER 2X 51.5-S M-NC	DUMPER 2X 51.5-S T	1.5	2	15.3	13.5	12.7	9.9	2.4	0	-	-	-	-	-	-	-	-
DUMPER 2X 52.2-S M-NC	DUMPER 2X 52.2-S T	2.2	3	19.0	16.5	15.4	14.1	12.5	11.3	9.6	7.7	5.5	3.4	1.9	0.6	0	-
-	DUMPER 2X 53-S T	3	4	20.0	17.6	16.4	15.1	13.9	12.5	11.1	9.7	8.4	6.9	5.4	3.7	2.5	0

Model (*)		P ₂		Capacity													
Single Phase	Three Phase	kW	HP	l/min	100	200	300	420	600	800	1050	1120	1150	1600	2130	2600	3000
				m ³ /h	6	12	18	25.2	36	48	63	67.2	69	96	127.8	156	180
				Head in m													
-	DUMPER 3X 53.7-S T	3.7	5	51.0	47.5	42.0	28.0	0	-	-	-	-	-	-	-	-	-
-	DUMPER 3X 53.7-M T	3.7	5	22.0	21.3	20.9	20.2	18.8	15.9	11.3	3.7	1.1	0	-	-	-	-
-	DUMPER 3X 53.7-L T	3.7	5	15.0	14.7	14.4	14.1	13.7	13.1	12.4	11.2	10.8	10.6	6.6	0	-	-
-	DUMPER 3X 55.5-S T	5.5	7.5	47.5	46.0	43.5	41.1	38.5	34.1	26.1	7.4	0	-	-	-	-	-
-	DUMPER 3X 55.5-M T	5.5	7.5	28.0	27.0	26.2	25.3	24.2	22.3	20.2	18.0	17.5	17.3	13.3	7.0	0	-
-	DUMPER 3X 57.5-S T	7.5	10	49.0	47.5	47.0	45.9	43.8	39.1	31.6	19.0	-	-	-	-	-	-
-	DUMPER 3X 57.5-M T	7.5	10	29.5	28.8	28.4	27.9	27.2	25.9	24.3	21.9	21.2	20.9	16.7	11.7	6.0	0

Model (*)		P ₂		Capacity													
Single Phase	Three Phase	kW	HP	l/min	200	400	600	800	1000	1250	1600	2000	2500	3000	3500	4000	4450
				m ³ /h	12	24	36	48	60	75	96	120	150	180	210	240	267
				Head in m													
-	DUMPER 4X 512-S T-SD	12	16	72.0	66.5	61.1	53.5	41.3	25.3	0	-	-	-	-	-	-	-
-	DUMPER 4X 512-M T-SD	12	16	33.0	32.0	30.8	29.5	28.4	27.4	26.0	23.7	20.9	18.3	14.8	10.3	5.1	0

Model (*)		P ₂		Capacity													
Single Phase	Three Phase	kW	HP	l/min	100	200	300	400	500	600	700	800	900	1000	1100	1150	1200
				m ³ /h	6	12	18	24	30	36	42	48	54	60	66	69	72
				Head in m													
-	DUMPER 5X 58-S	8	10.7	68.0	67.0	64.0	60.1	56.0	50.3	44.8	39.5	34.0	29.0	22.6	12.6	0	-

Model (*)		P ₂		Capacity													
Single Phase	Three Phase	kW	HP	l/min	500	1000	1500	2170	2280	3000	3750	4500	5250	6000	7100	8000	8600
				m ³ /h	30	60	90	130.2	136.8	180	225	270	315	360	426	480	516
				Head in m													
-	DUMPER 6X 519-S T-SD	19	25	78.7	72.9	63.7	44.8	0	-	-	-	-	-	-	-	-	-
-	DUMPER 6X 519-M T-SD	19	25	39.0	36.9	34.4	31.7	28.5	28.0	24.6	20.4	15.1	8.3	0	-	-	-
-	DUMPER 6X 526-S T-SD	26	35	83.0	75.1	63.9	48.3	11.3	0	-	-	-	-	-	-	-	-
-	DUMPER 6X 526-M T-SD	26	35	45.0	42.7	41.0	39.2	36.0	35.0	30.8	28.5	24.7	19.3	12.5	0	-	-
-	DUMPER 6X 537-M T-SD	37	50	47.0	44.5	41.8	39.5	37.0	36.5	33.8	31.6	28.8	26.4	23.6	17.0	7.9	0

Model (*)		P ₂		Capacity													
Single Phase	Three Phase	kW	HP	l/min	400	800	1200	1500	1800	2100	2400	2700	3000	3300	3600	3900	4200
				m ³ /h	24	48	72	90	108	126	144	162	180	198	216	234	252
				Head in m													
-	DUMPER 7X 537-S T-SD	37	50	88.0	85.8	82.7	78.6	75.1	71.1	66.0	59.1	51.4	42.8	33.4	23.1	12.0	0

(*) Replace letter "X" in pump name with:
 "0" for Mody "SLIMLINE" type;
 "0L" for Mody "SLIMLINE" type in AISI 316;
 "1" for Mody "INDUSTRIAL SIDE DISCHARGE" type.

TYPE KEY

50Hz

Rev. 0

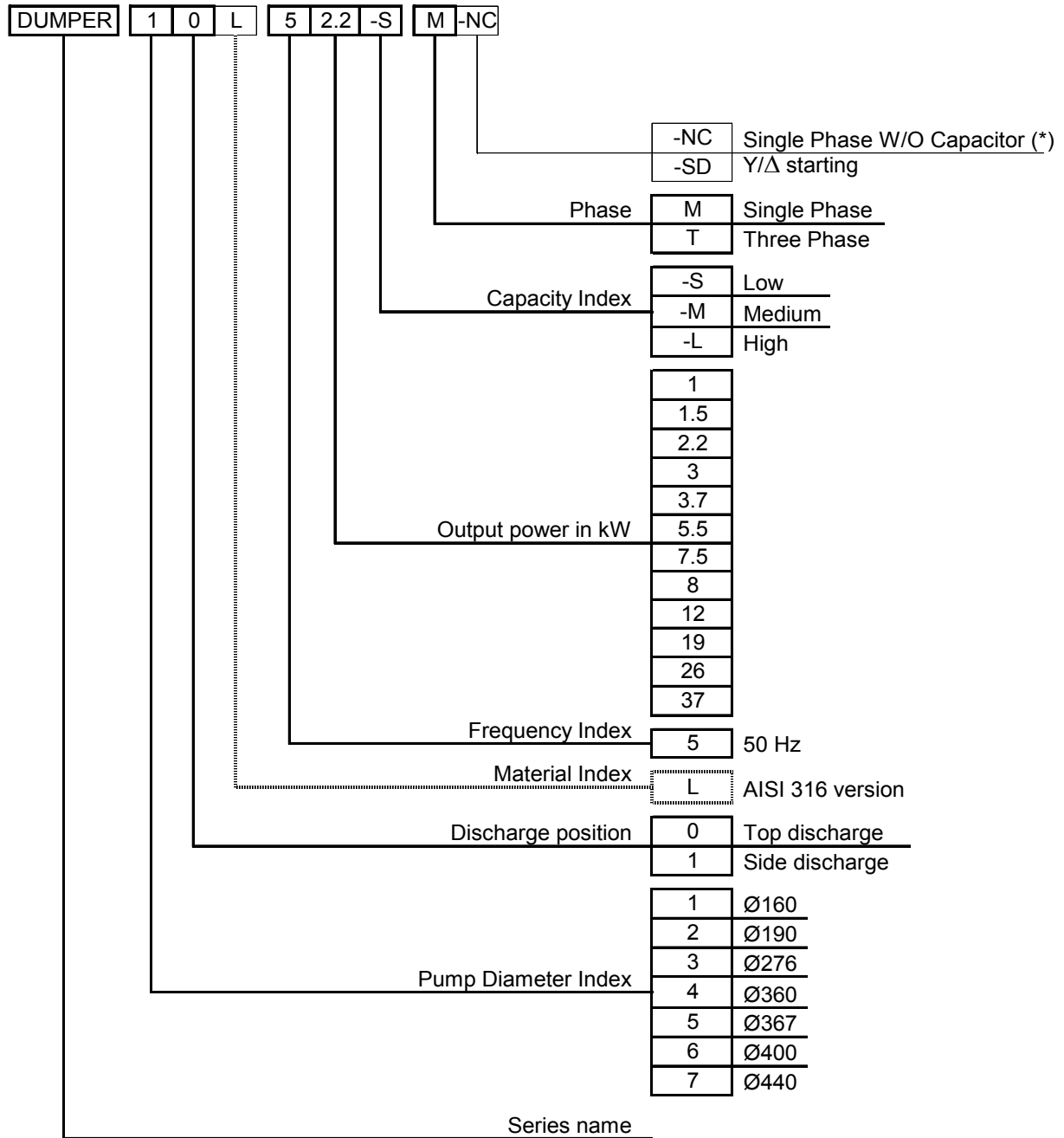

*Requires control panel

PERFORMANCE CURVE SPECIFICATIONS

The specifications below qualify the curves shown on the following pages.

- ◆ Tolerances according to ISO 9906 Annex A
- ◆ The curves refer to effective speed of asynchronous motors at 50 Hz
- ◆ Measurements were carried out with clean water at 20°C of temperature and with a kinematic viscosity of $\nu = 1 \text{ mm}^2/\text{s}$ (1 cSt)
- ◆ Symbols explanation:

Q = volume flow rate

H = total head

P_1 = pump power input

μ = pump efficiency

DUMPER 1X 51-S

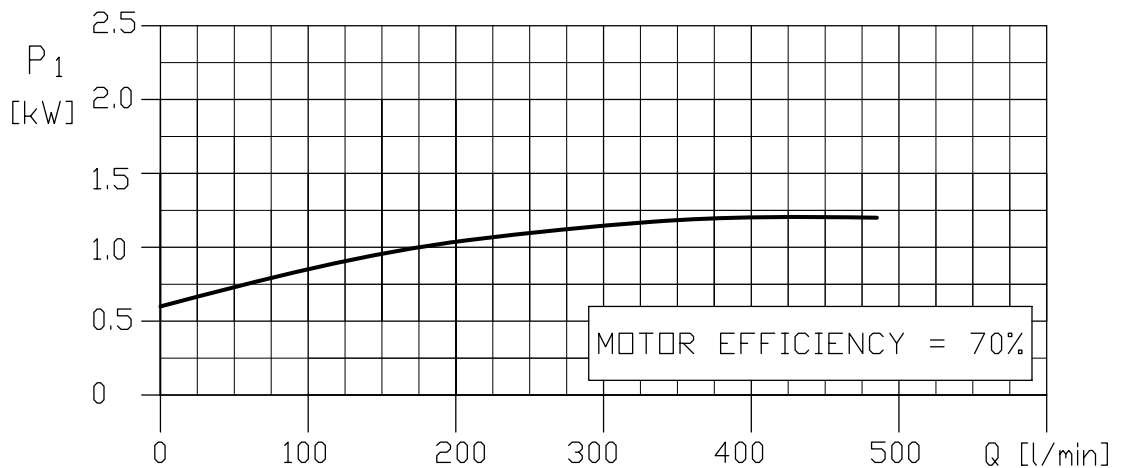
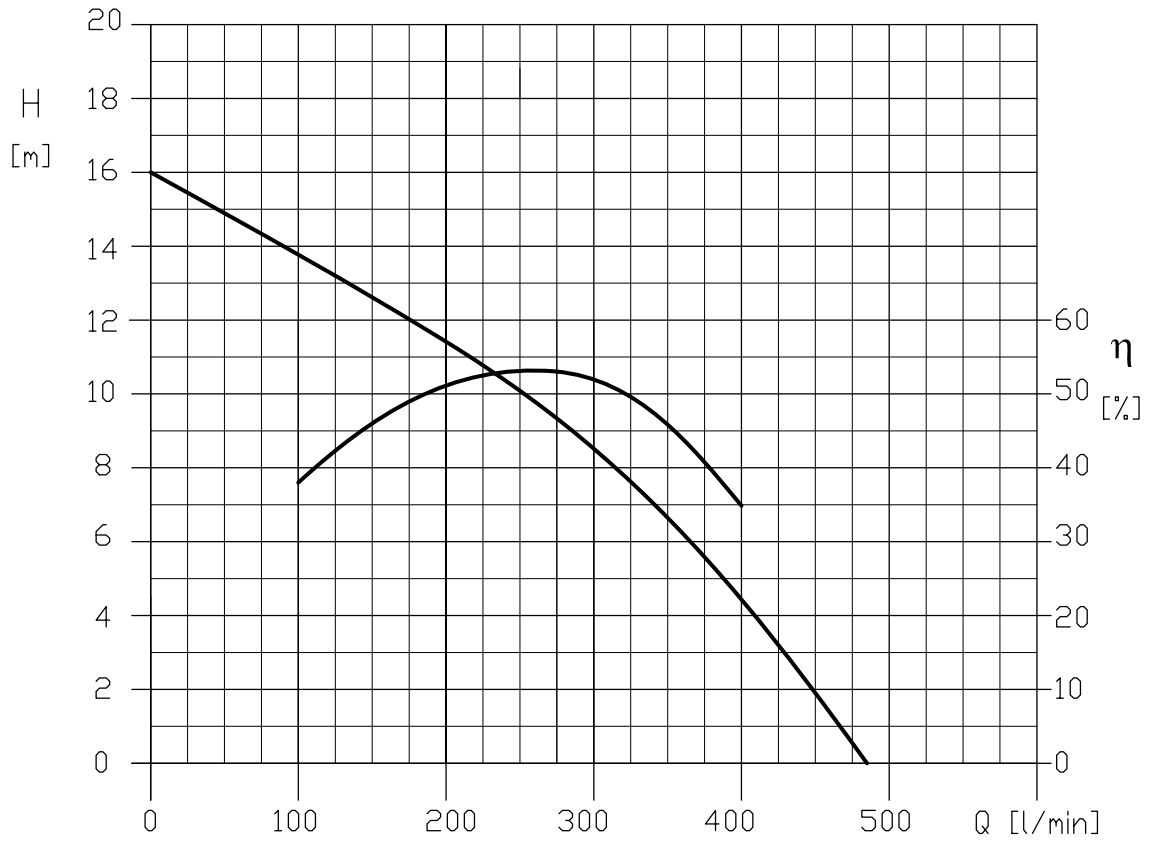

Rotation speed $\approx 2800 \text{ min}^{-1}$
 Test standard: ISO 9906 – Annex A

DUMPER 1X 51.5-S

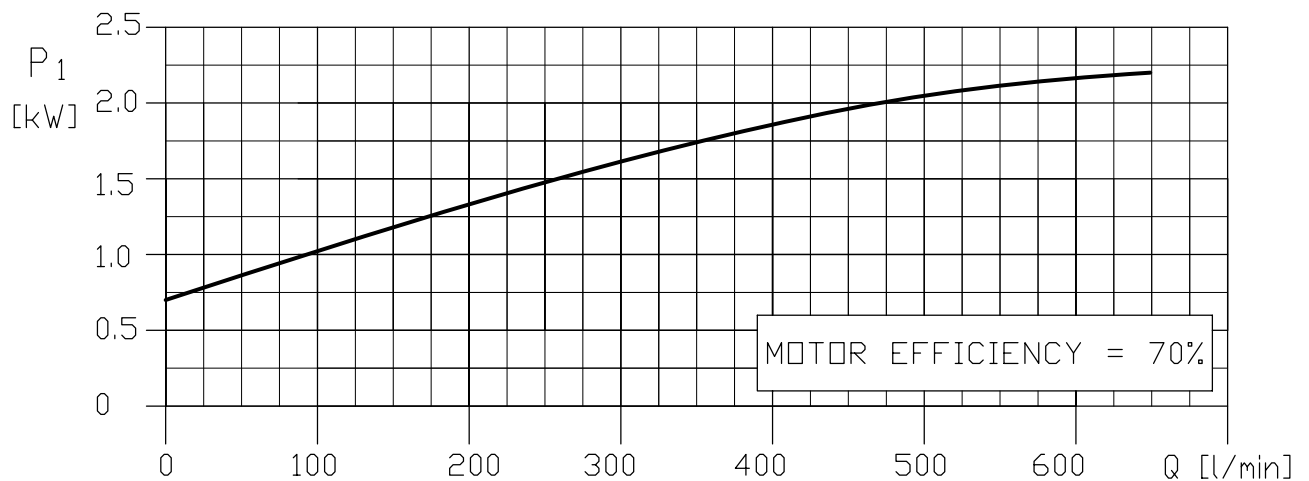
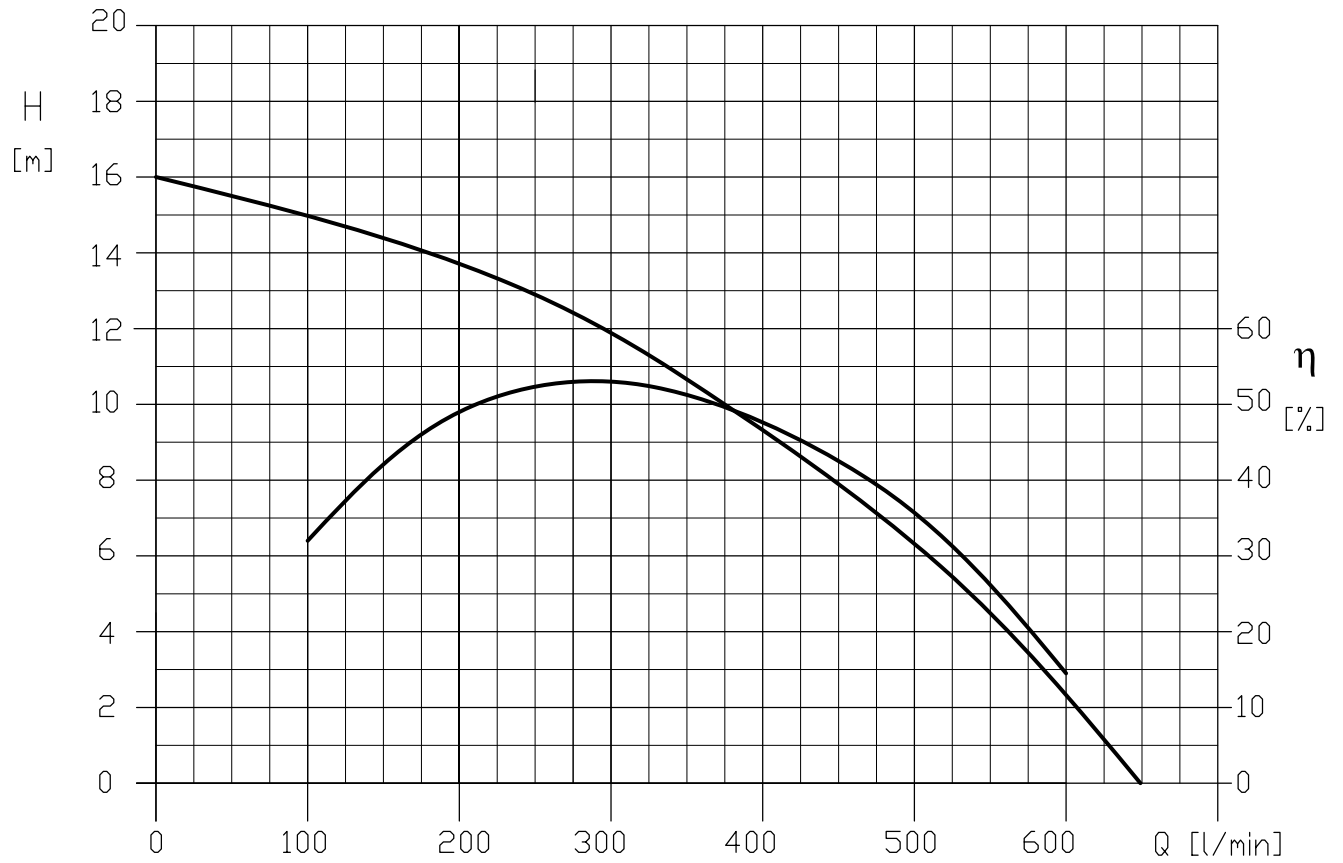

Rotation speed $\approx 2800 \text{ min}^{-1}$
 Test standard: ISO 9906 – Annex A

DUMPER 2X 51.5-S

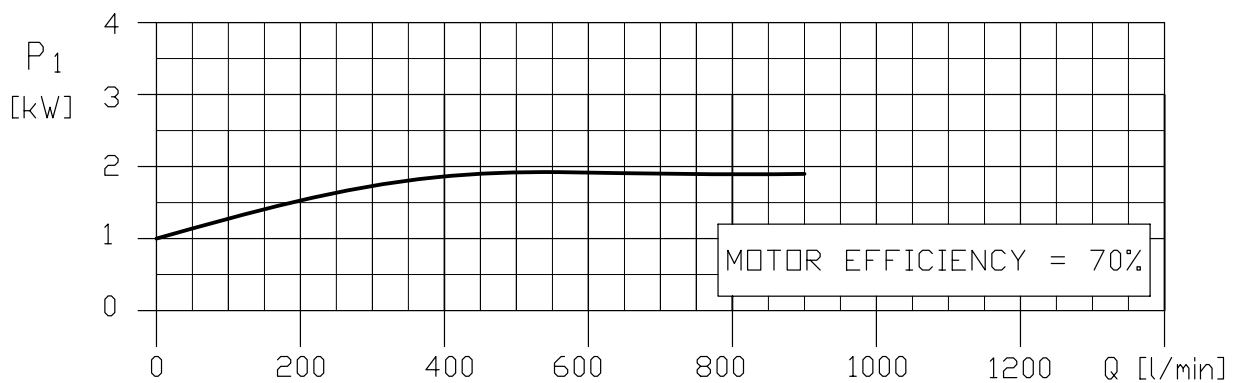
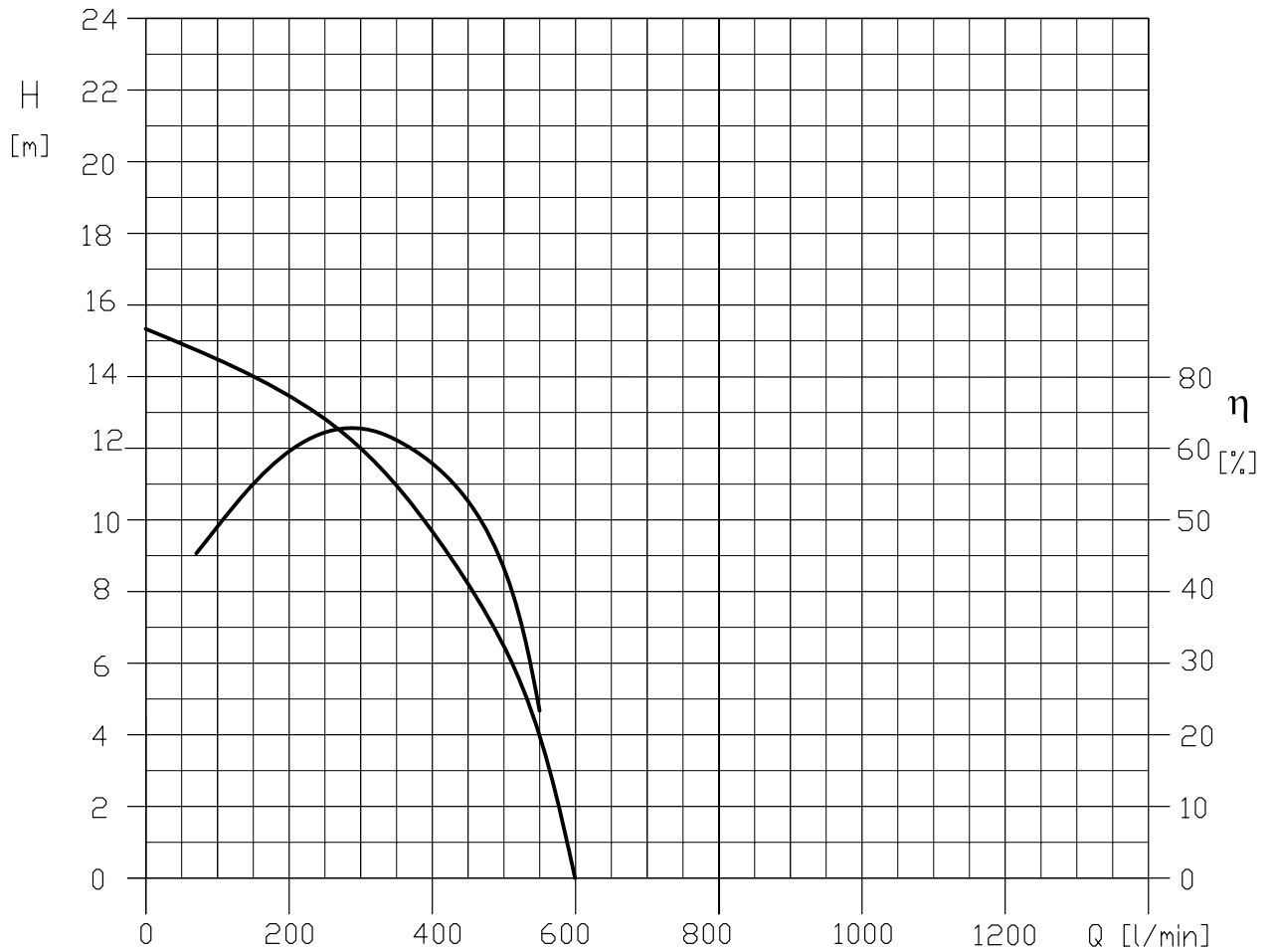

Rotation speed ≈ 2800 min⁻¹
 Test standard: ISO 9906 – Annex A

DUMPER 2X 52.2-S

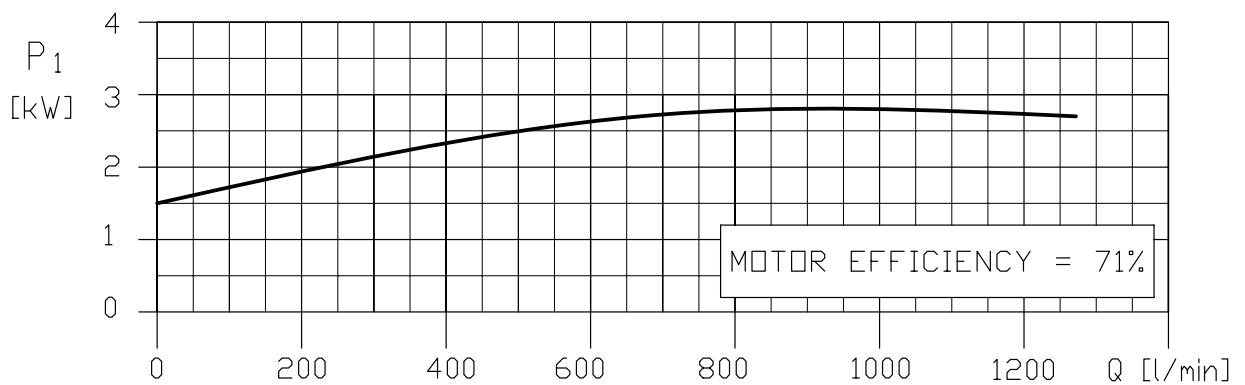
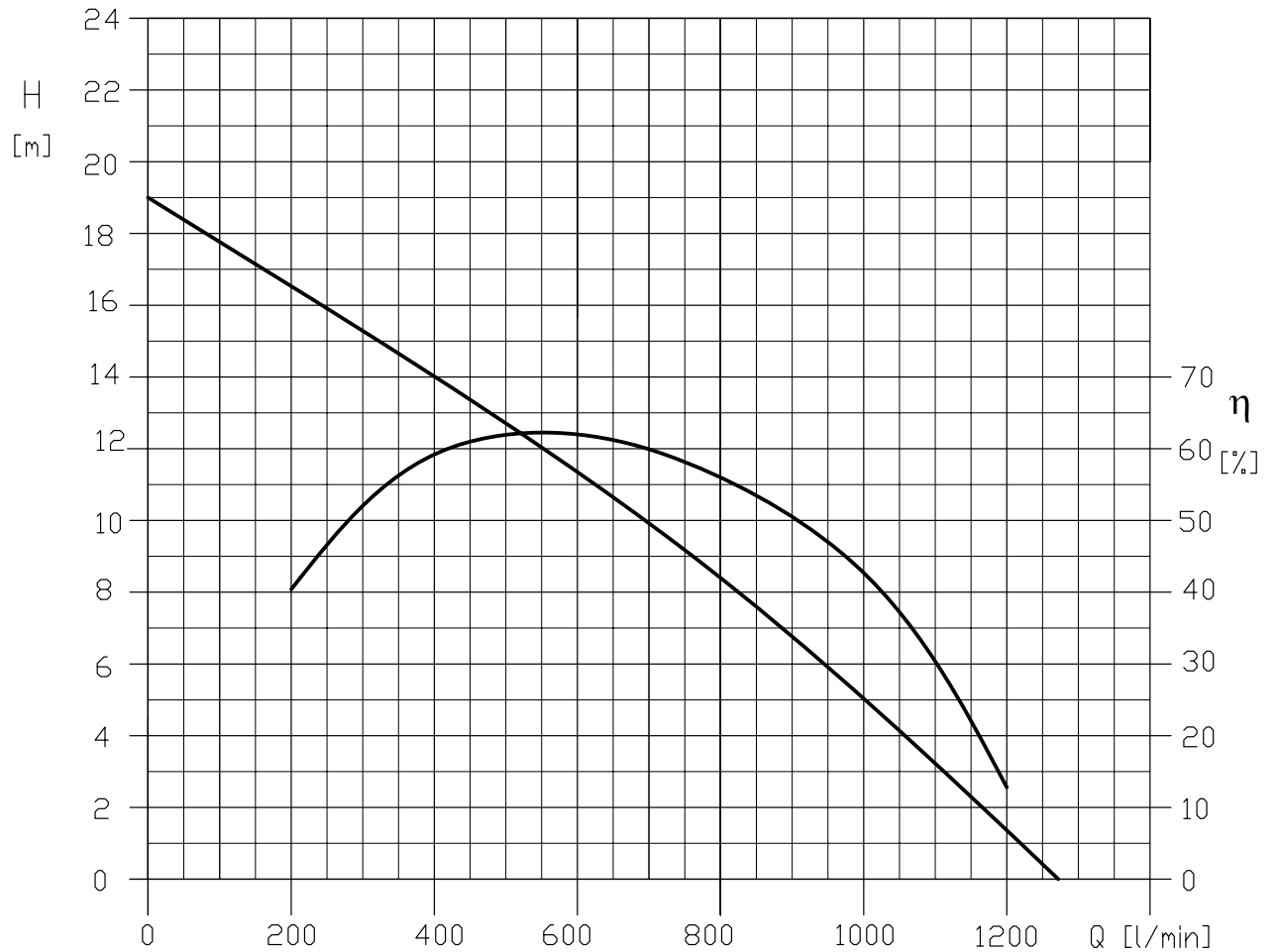

Rotation speed $\approx 2800 \text{ min}^{-1}$
 Test standard: ISO 9906 – Annex A

DUMPER 2X 53-S

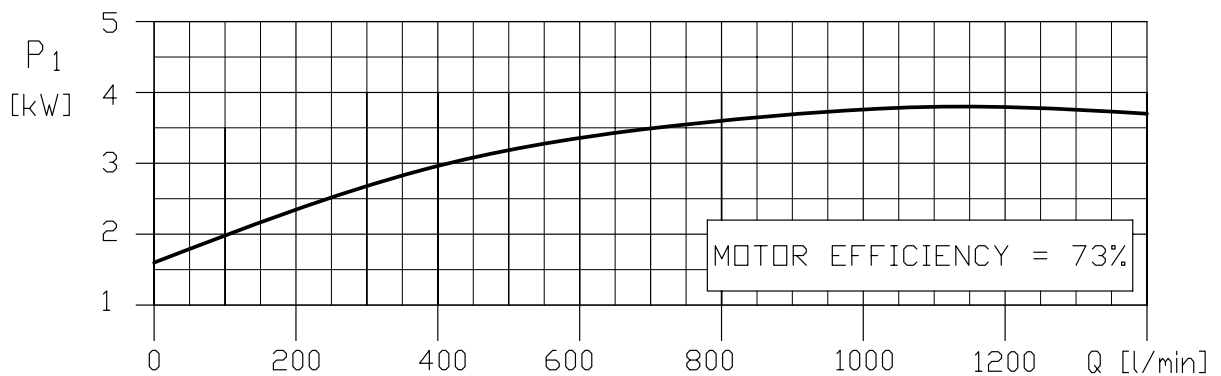
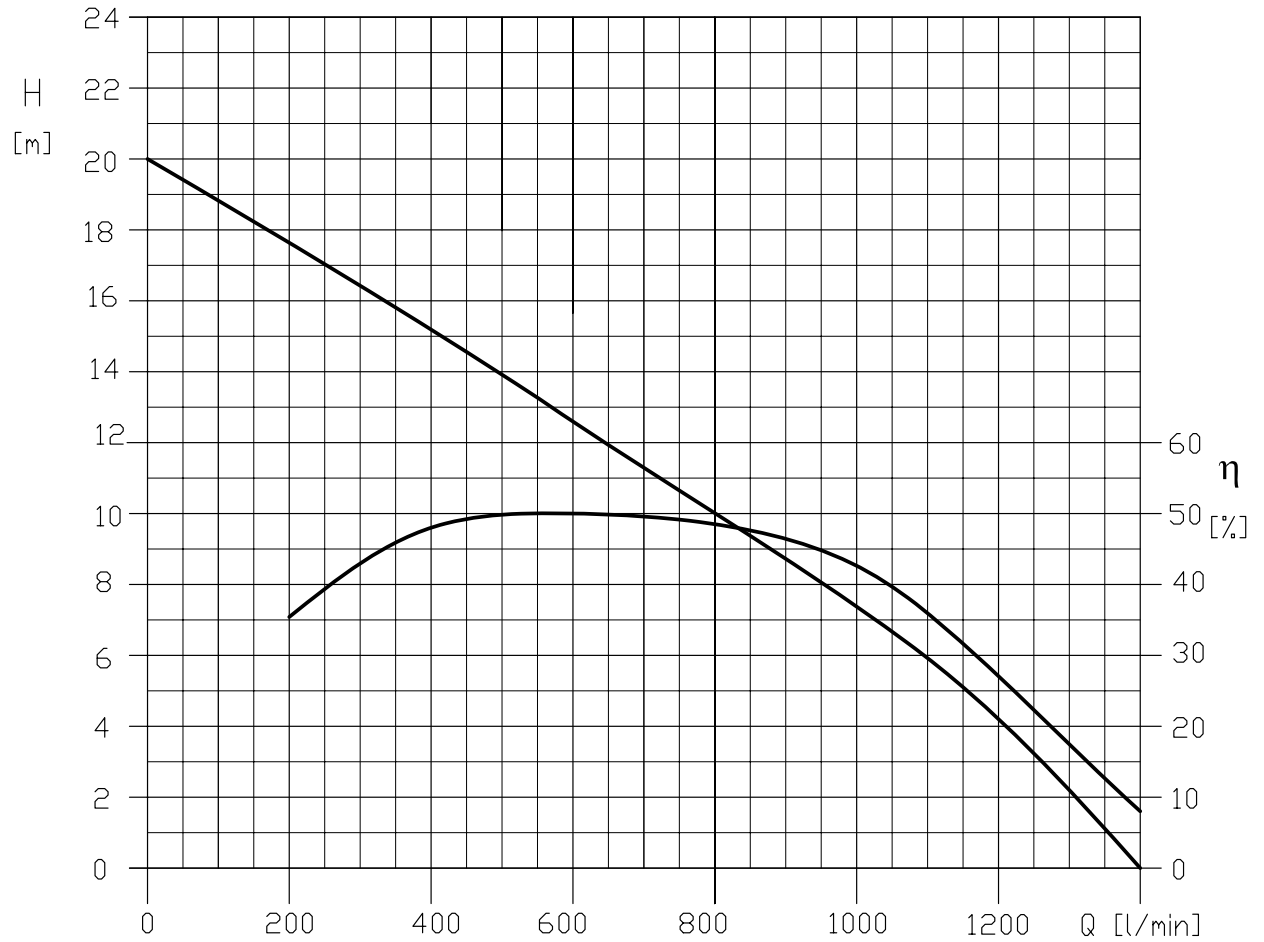

Rotation speed $\approx 2800 \text{ min}^{-1}$
 Test standard: ISO 9906 – Annex A

DUMPER 3X 53.7-S

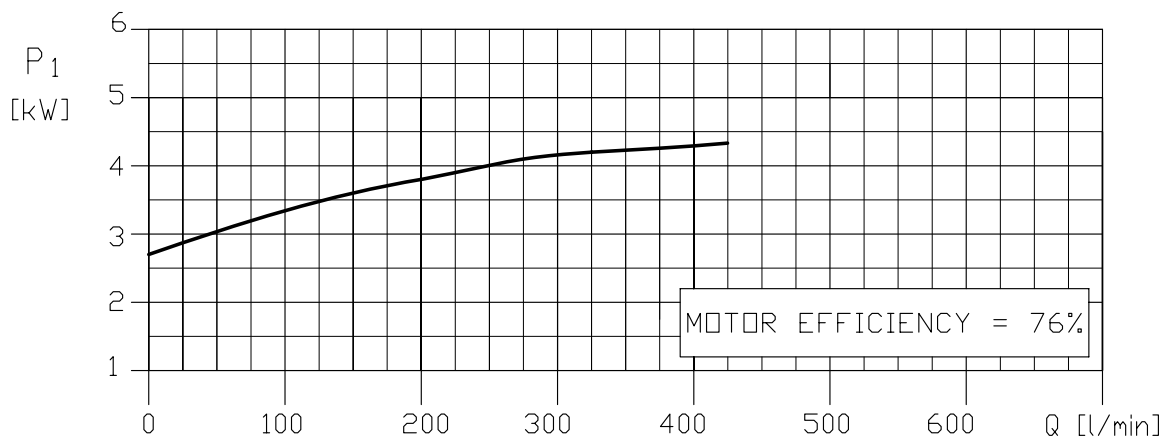
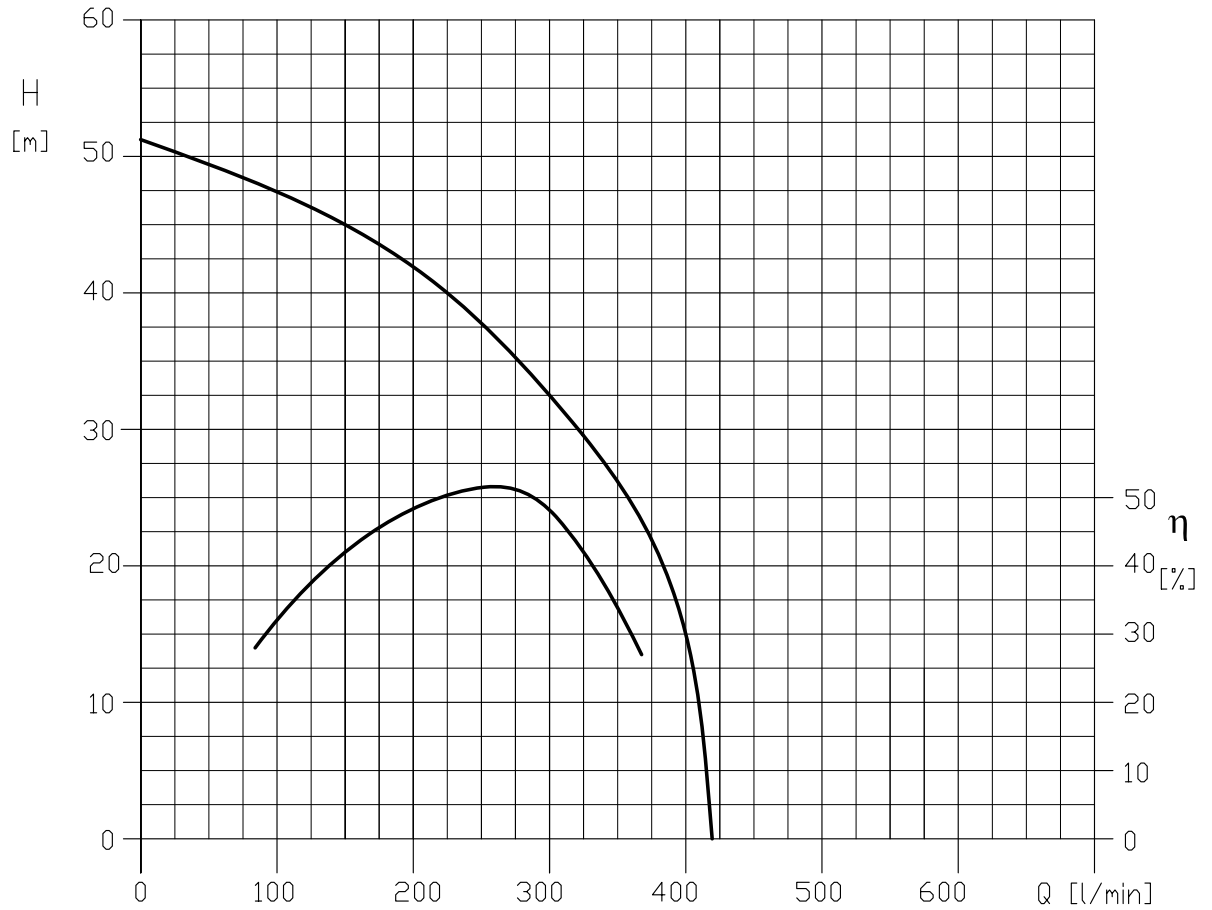

Rotation speed $\approx 2800 \text{ min}^{-1}$
Test standard: ISO 9906 – Annex A

DUMPER 3X 53.7-M

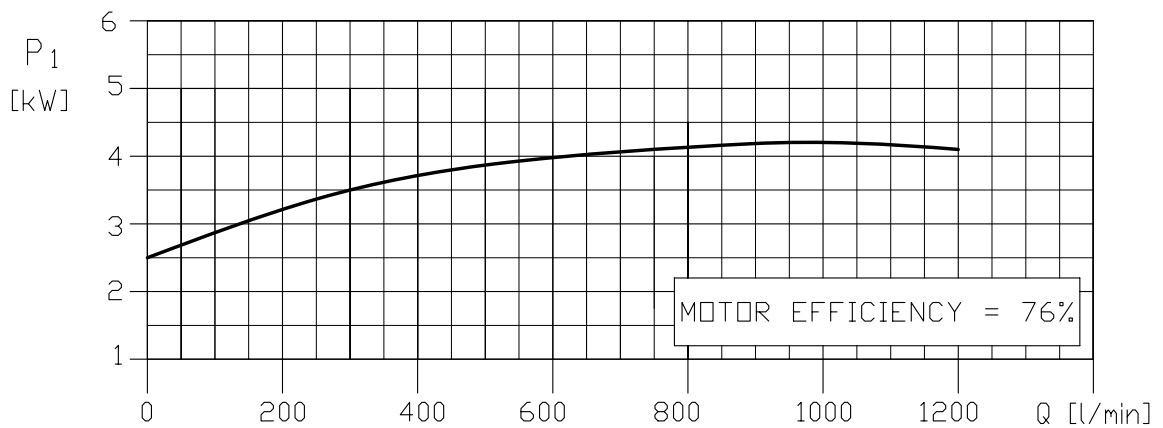
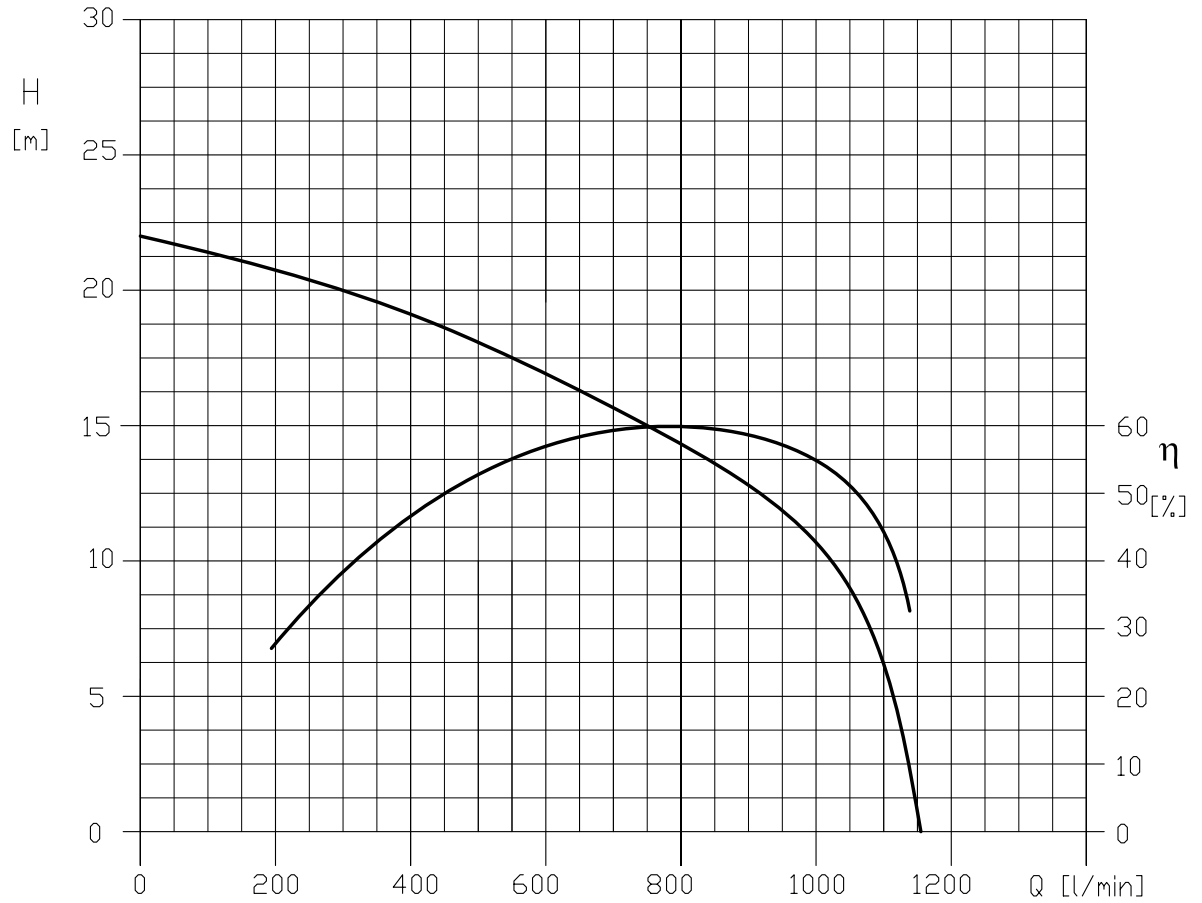

Rotation speed $\approx 2800 \text{ min}^{-1}$
Test standard: ISO 9906 – Annex A

DUMPER 3X 53.7-L

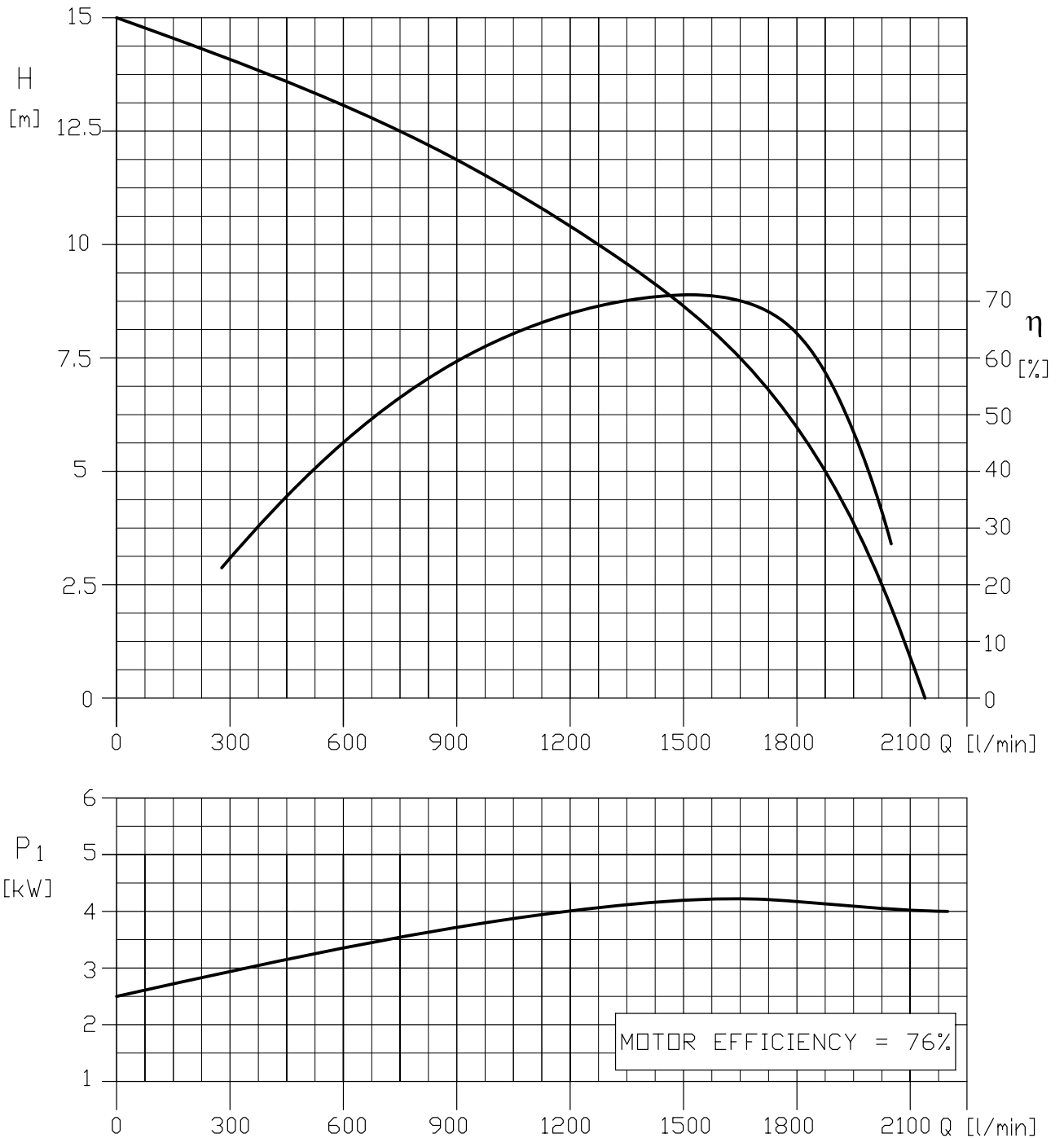

Rotation speed ≈ 2800 min⁻¹
 Test standard: ISO 9906 – Annex A

DUMPER 3X 55.5-S

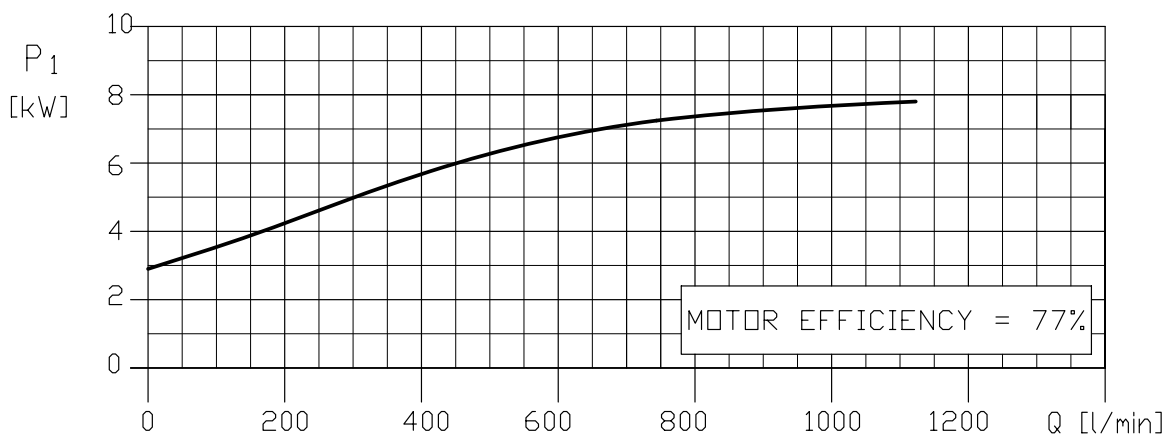

Rotation speed $\approx 2800 \text{ min}^{-1}$
 Test standard: ISO 9906 – Annex A

DUMPER 3X 55.5-M

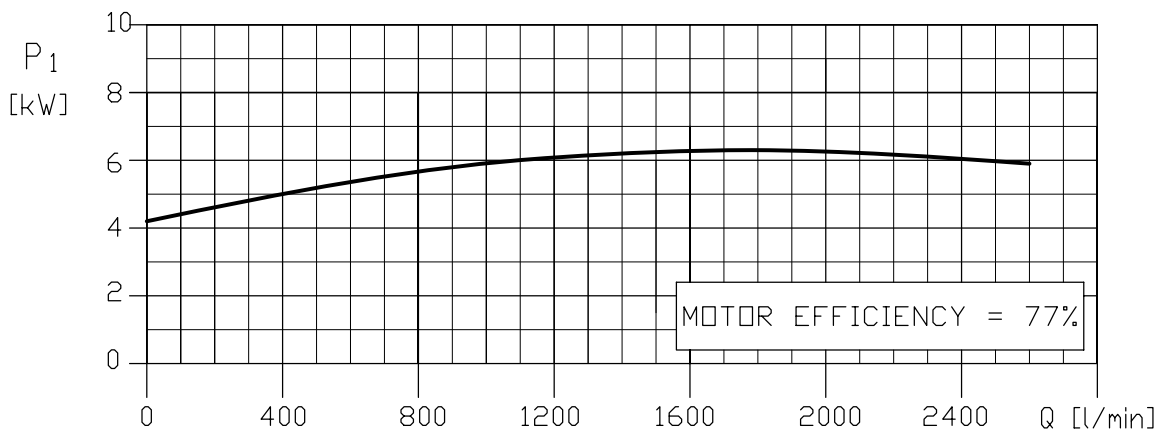

Rotation speed $\approx 2800 \text{ min}^{-1}$
Test standard: ISO 9906 – Annex A

DUMPER 3X 57.5-S

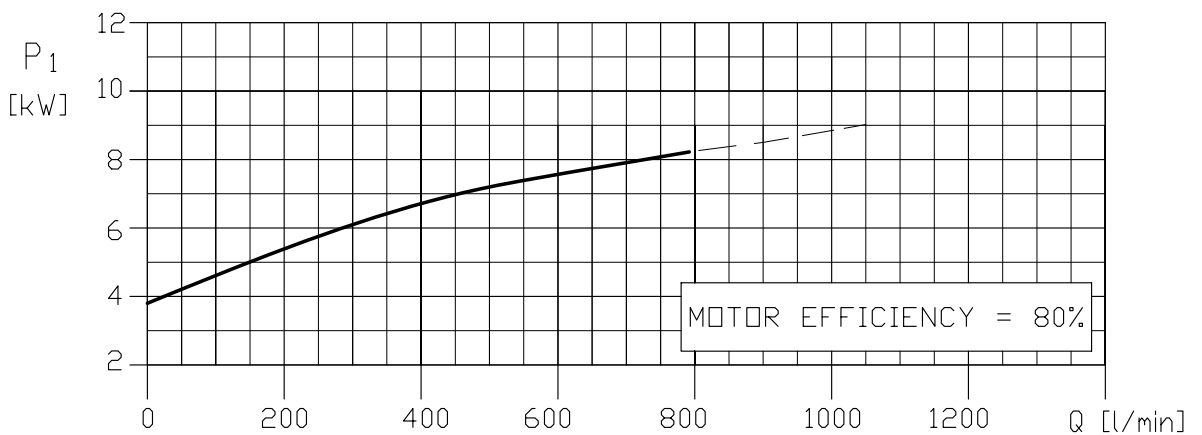

Rotation speed $\approx 2800 \text{ min}^{-1}$
Test standard: ISO 9906 – Annex A

DUMPER 3X 57.5-M

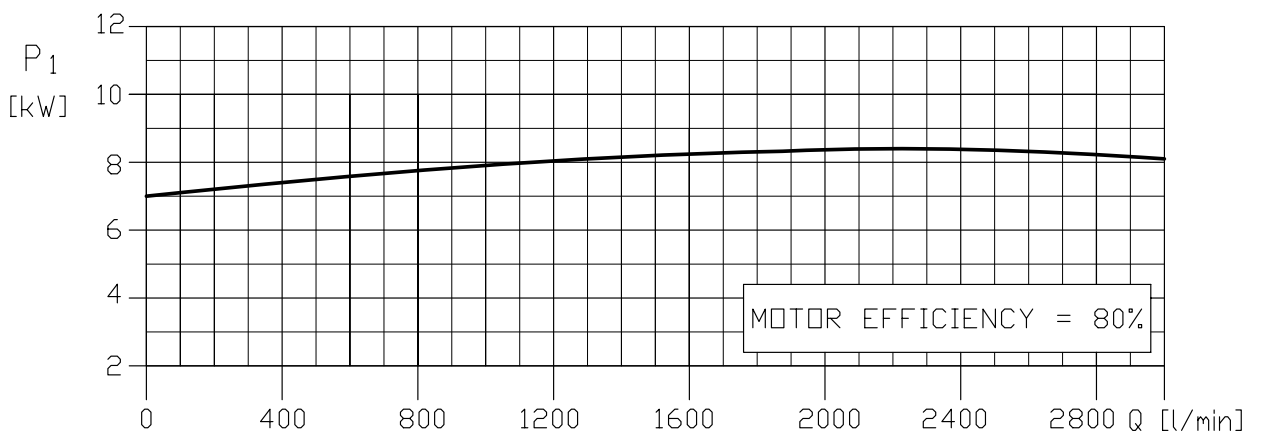

Rotation speed ≈ 2800 min⁻¹
Test standard: ISO 9906 – Annex A

DUMPER 4X 512-S

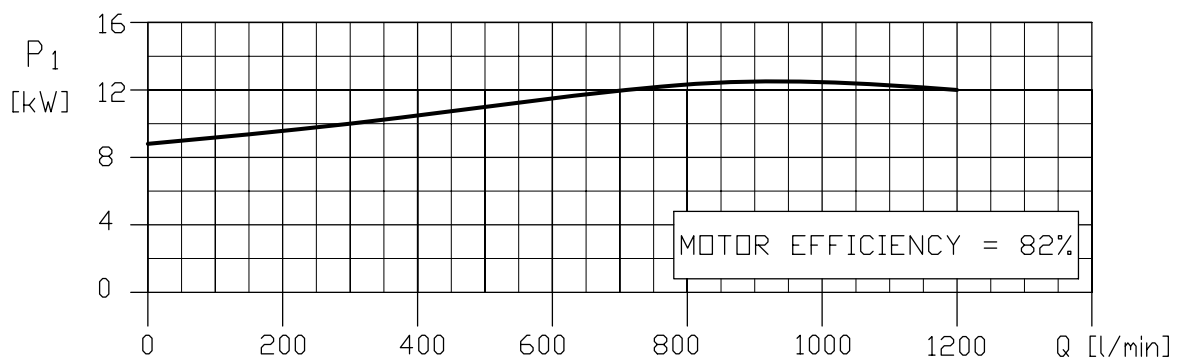
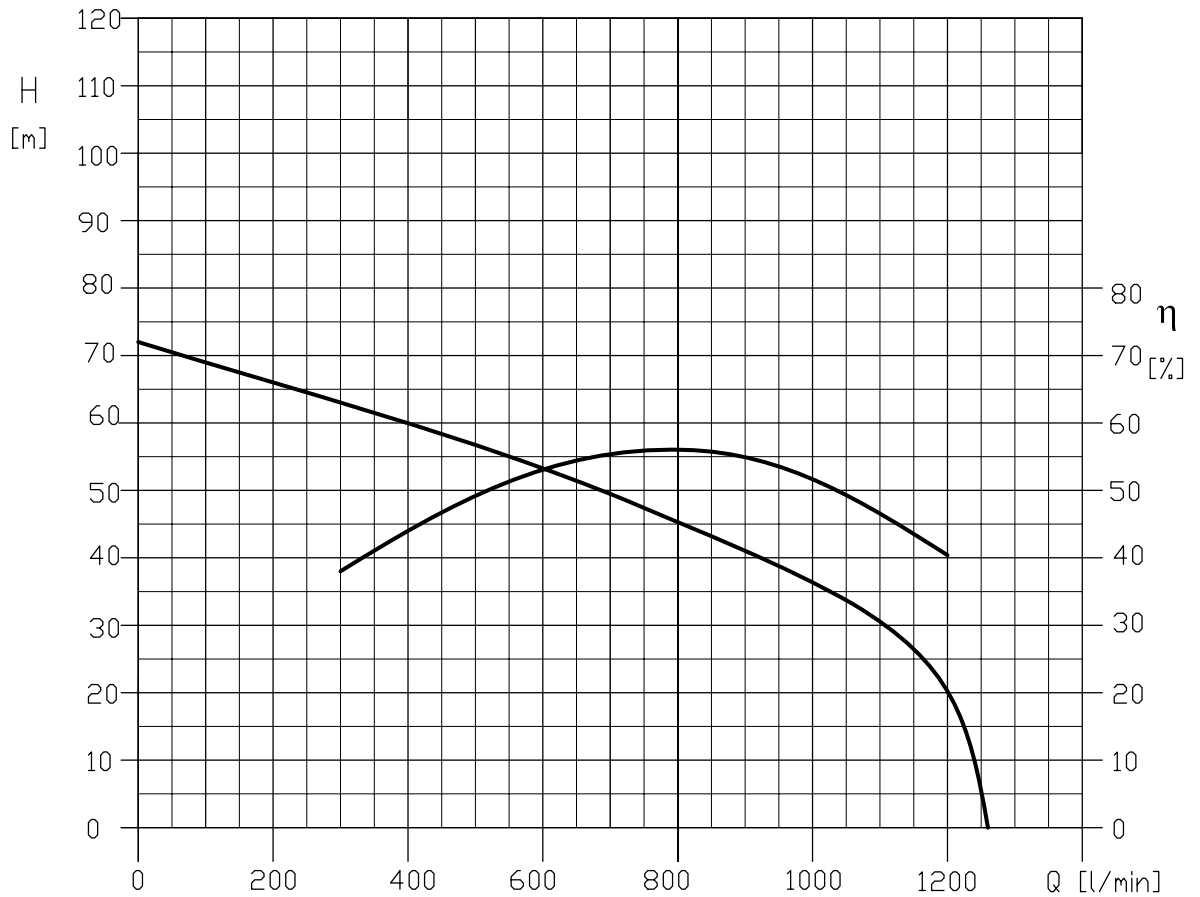

Rotation speed ≈ 2800 min⁻¹
 Test standard: ISO 9906 – Annex A

DUMPER 4X 512-M

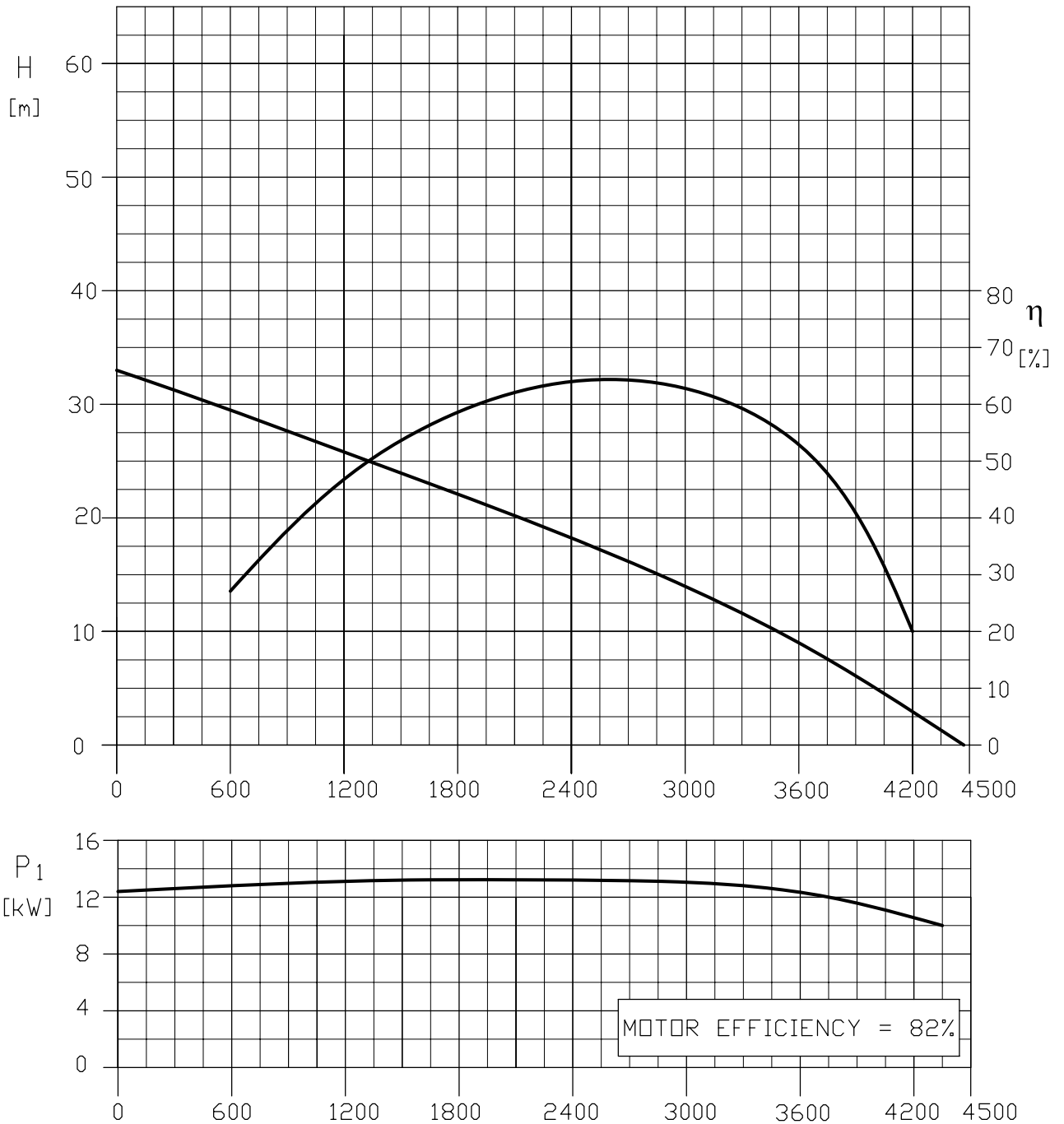

Rotation speed ≈ 2800 min⁻¹
Test standard: ISO 9906 – Annex A

DUMPER 5X 58-S

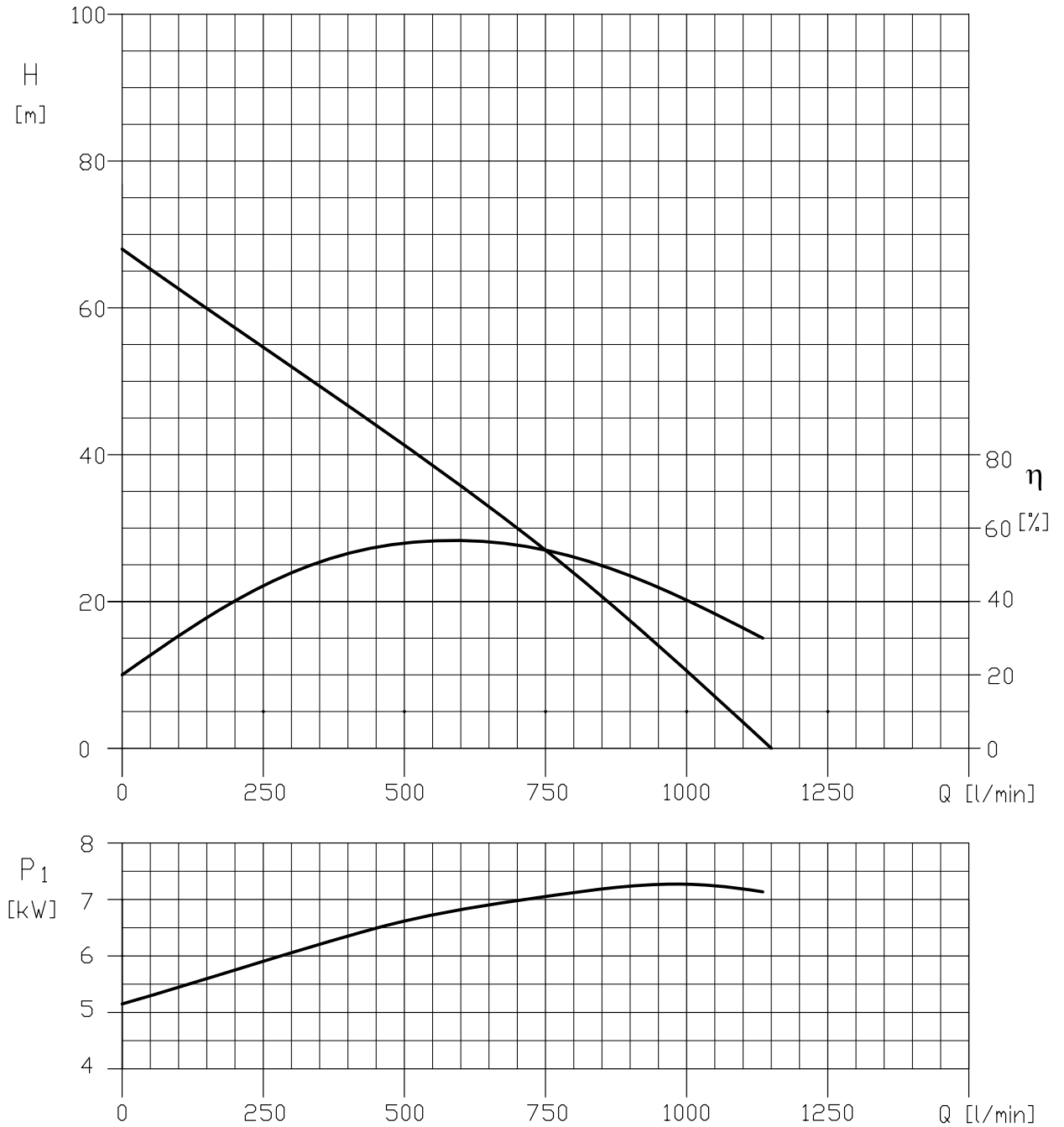

Rotation speed $\approx 2800 \text{ min}^{-1}$
Test standard: ISO 9906 – Annex A

DUMPER 6X 519-S

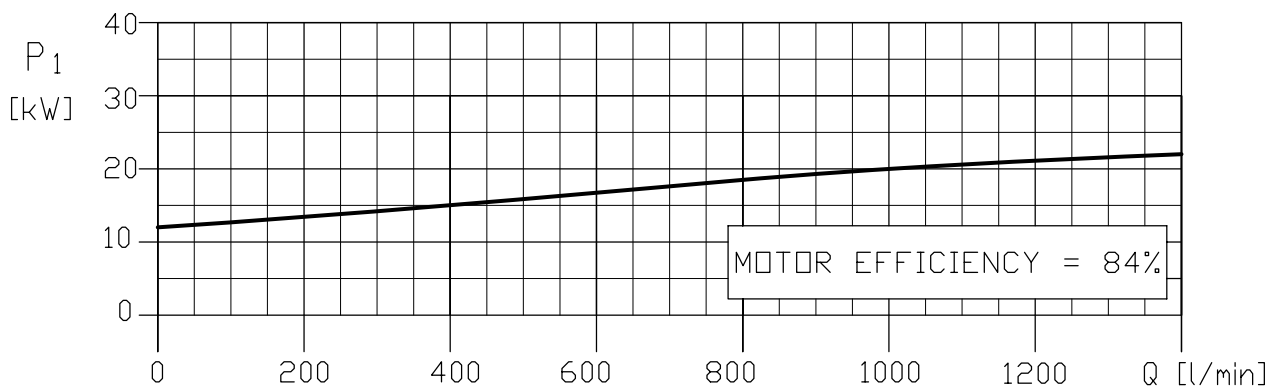
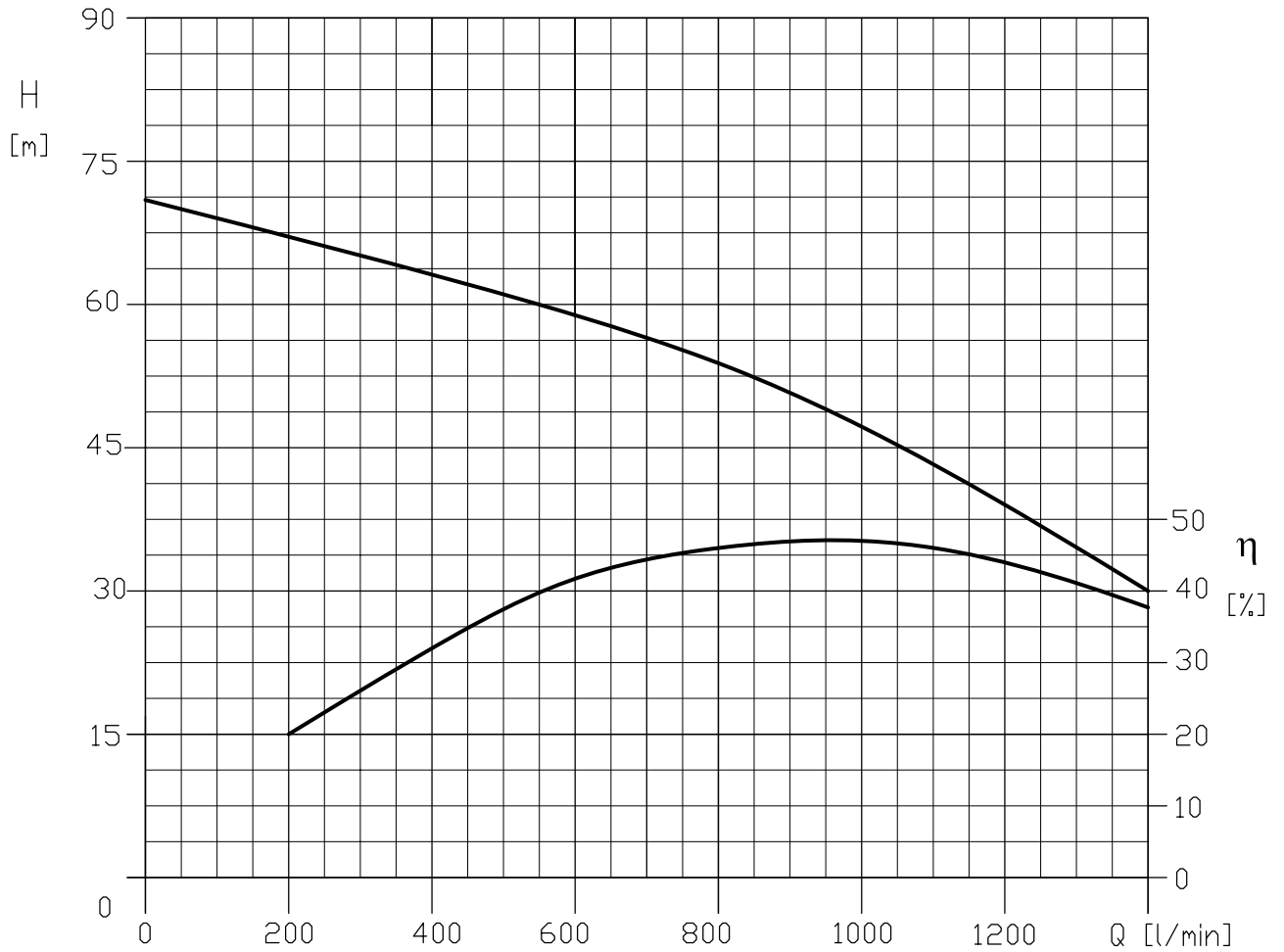

Rotation speed $\approx 2800 \text{ min}^{-1}$
 Test standard: ISO 9906 – Annex A

DUMPER 6X 519-M

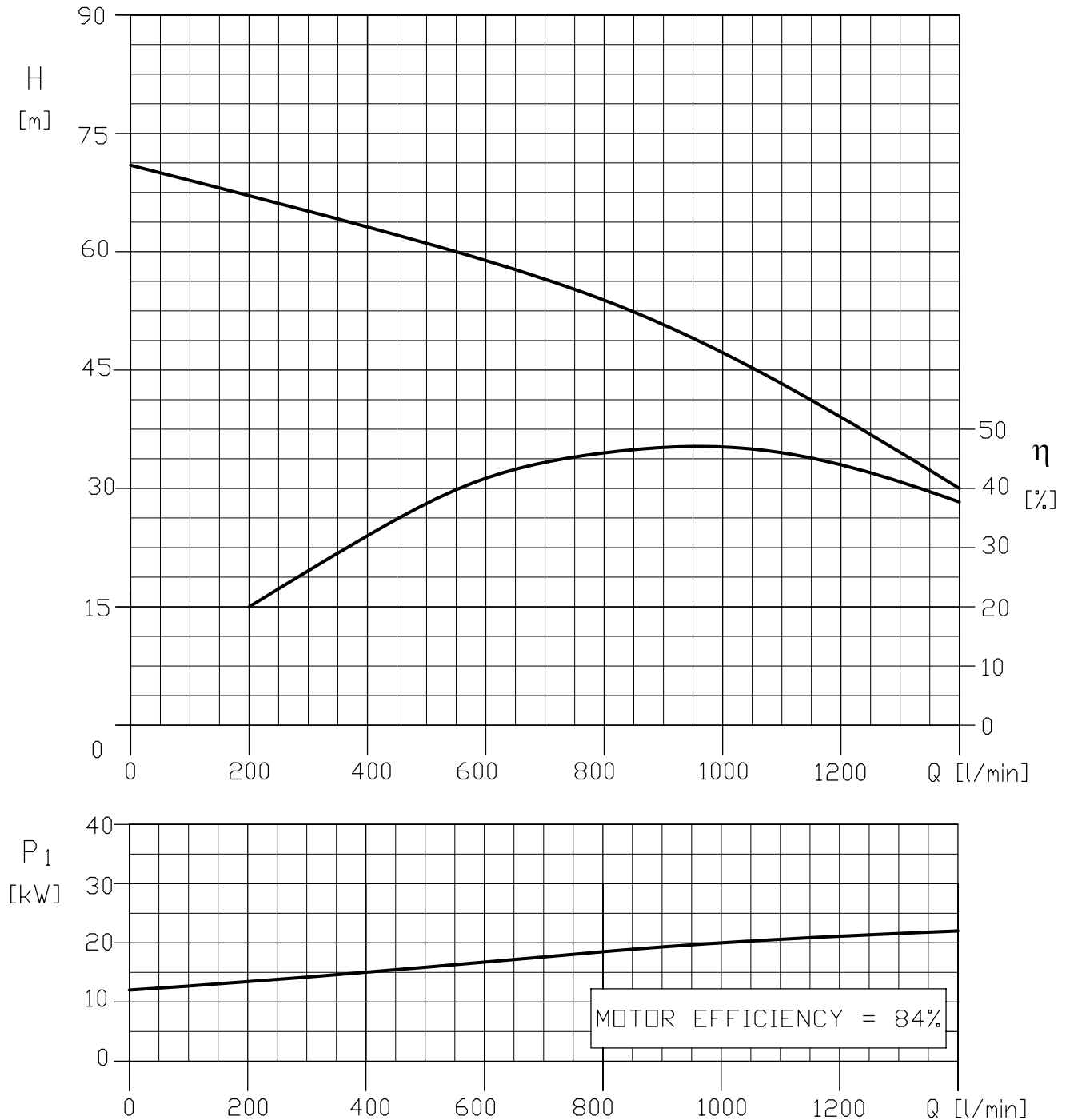

Rotation speed $\approx 2800 \text{ min}^{-1}$
 Test standard: ISO 9906 – Annex A

DUMPER 6X 526-S

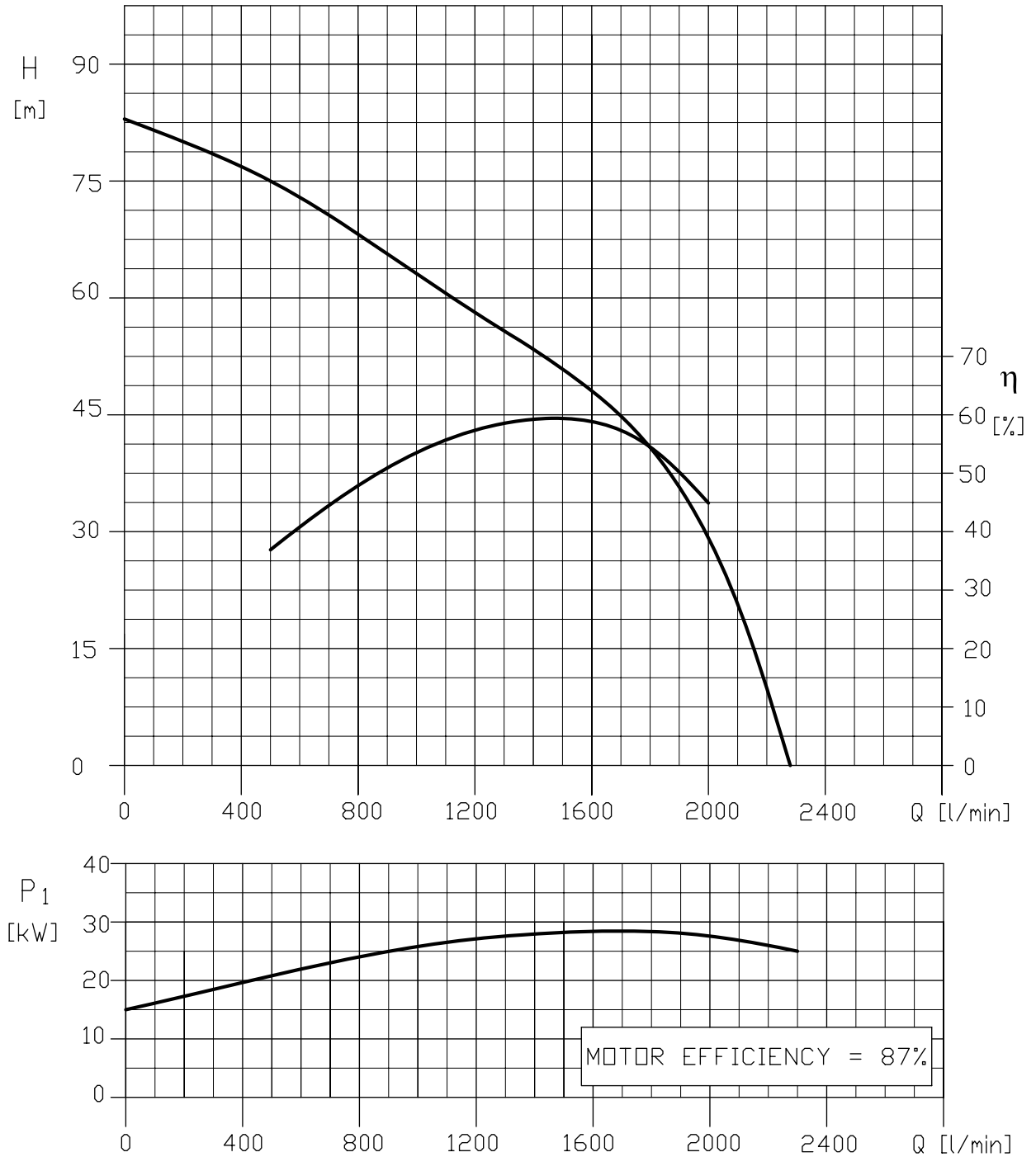

Rotation speed ≈ 2800 min⁻¹
Test standard: ISO 9906 – Annex A

DUMPER 6X 526-M

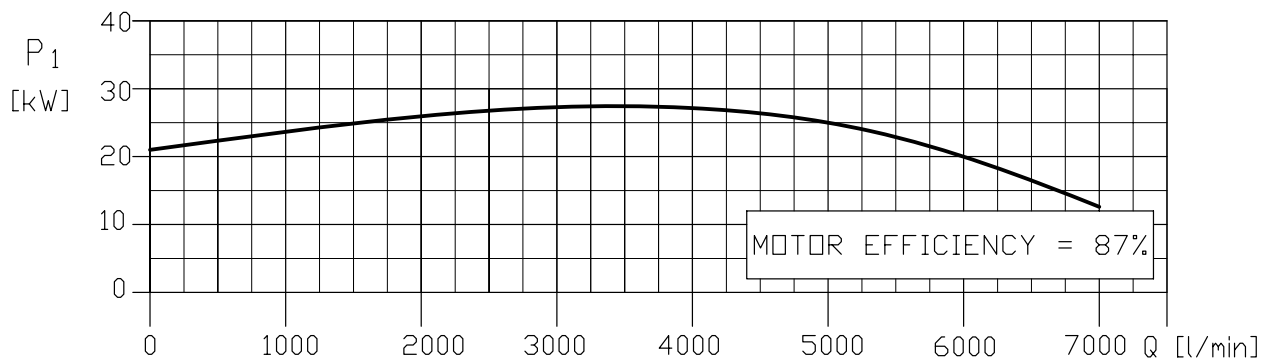
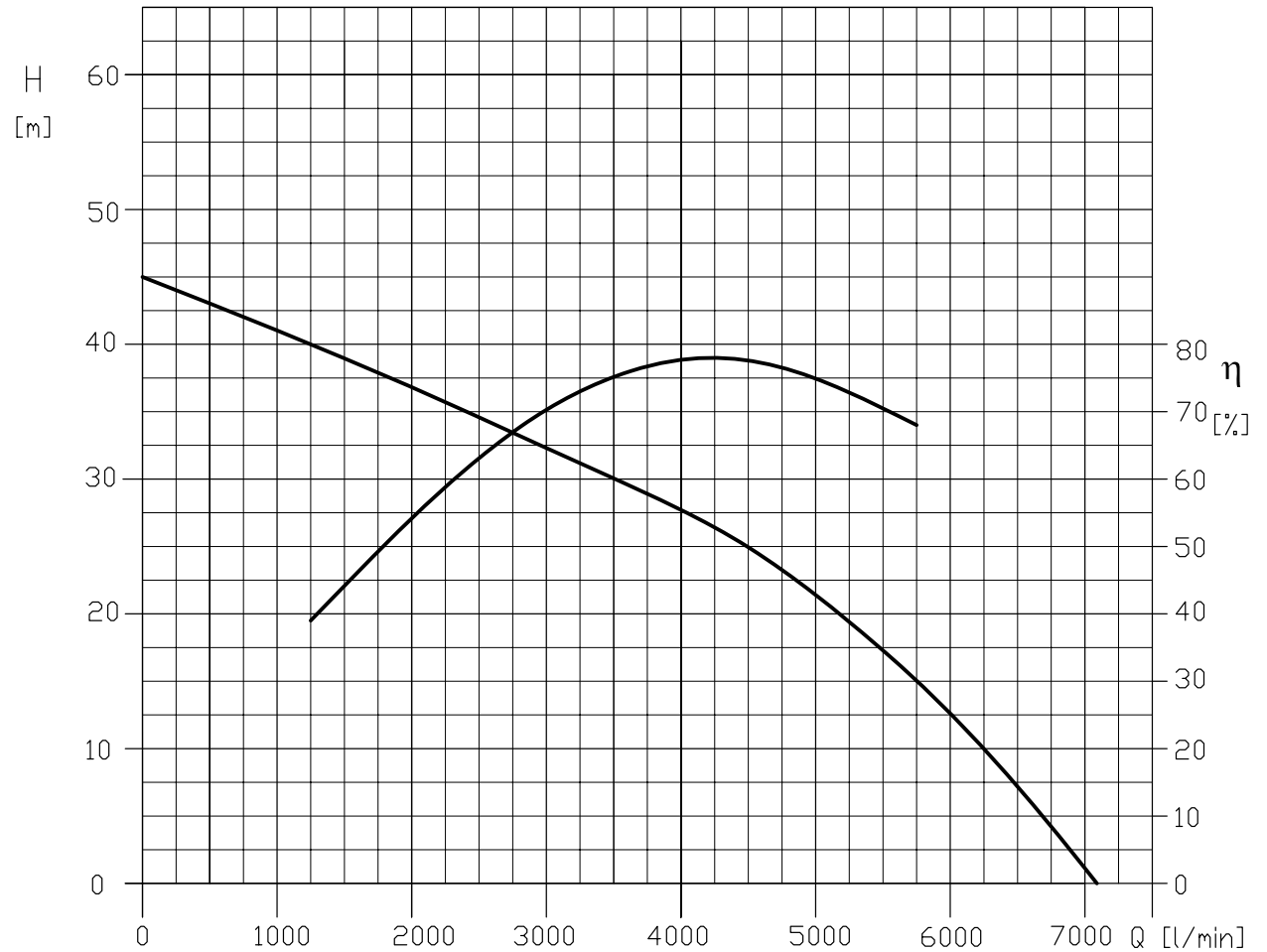

Rotation speed $\approx 2800 \text{ min}^{-1}$
 Test standard: ISO 9906 – Annex A

DUMPER 6X 537-M

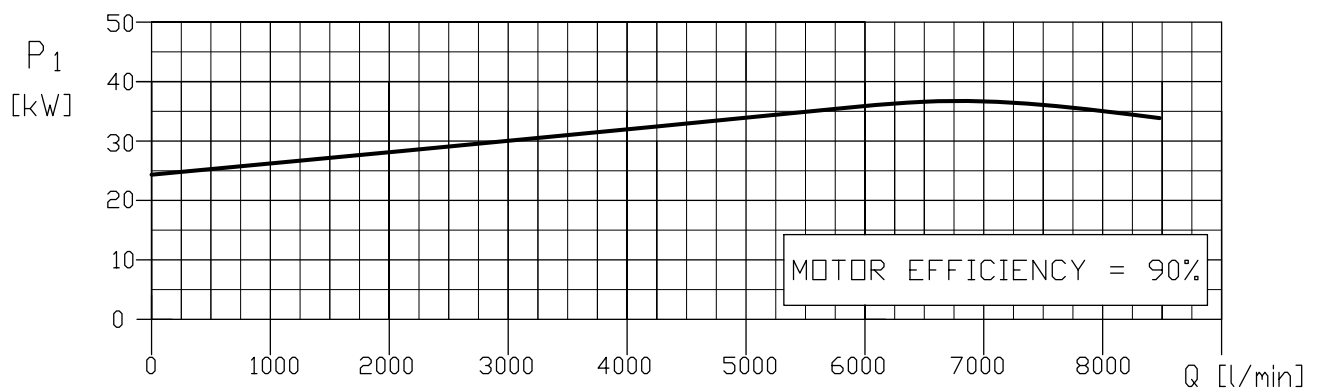
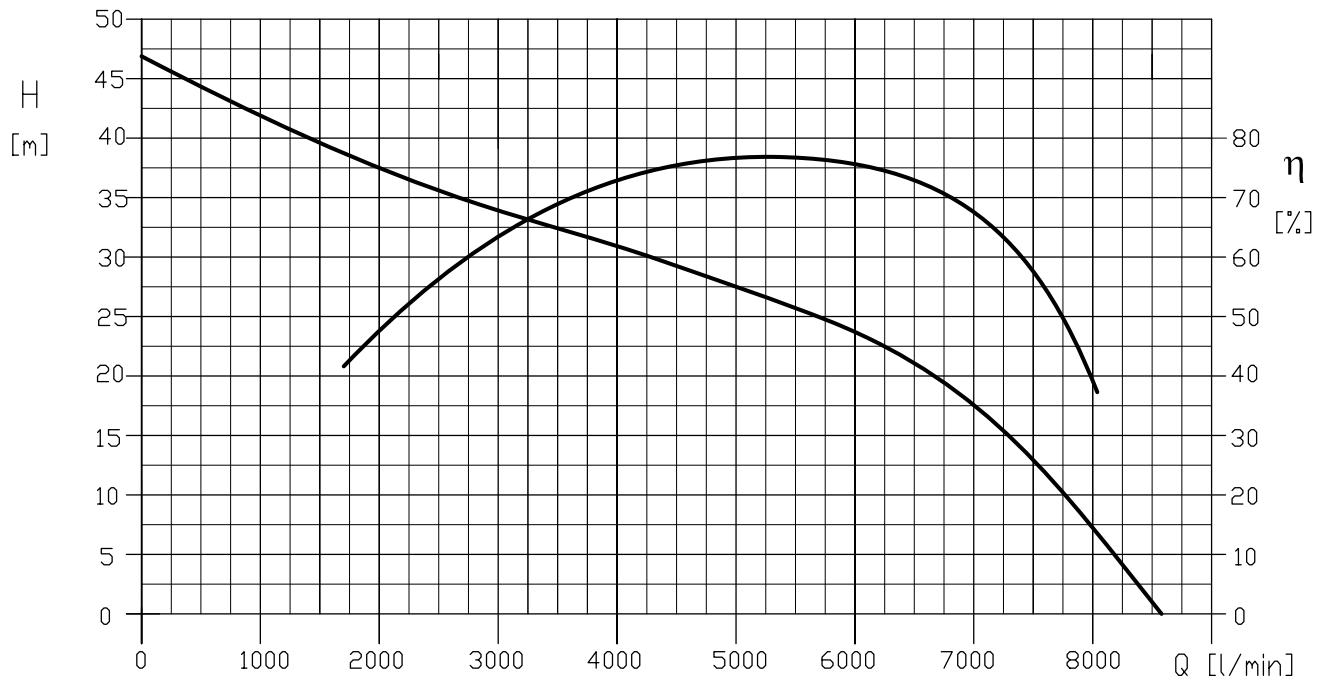

Rotation speed ≈ 2800 min⁻¹
 Test standard: ISO 9906 – Annex A

DUMPER 7X 537-S

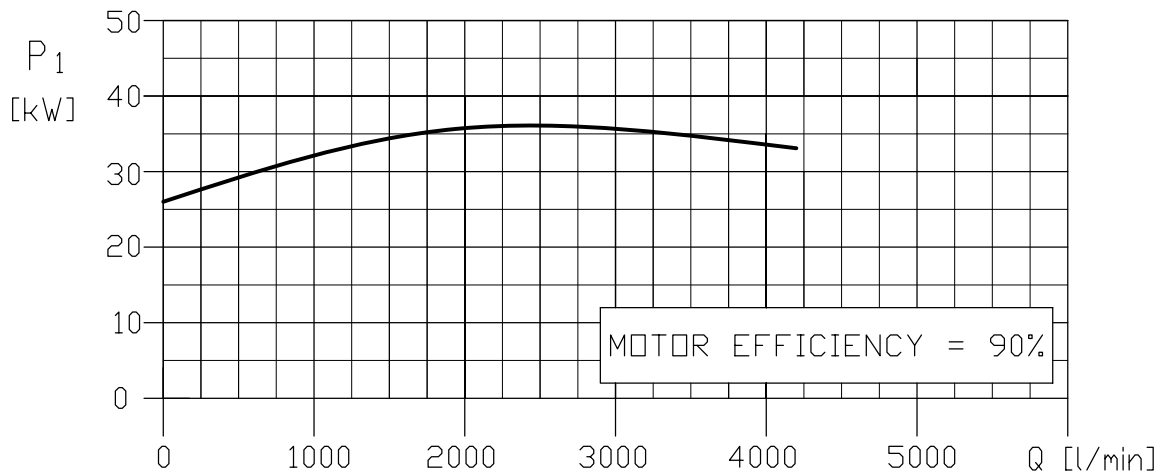
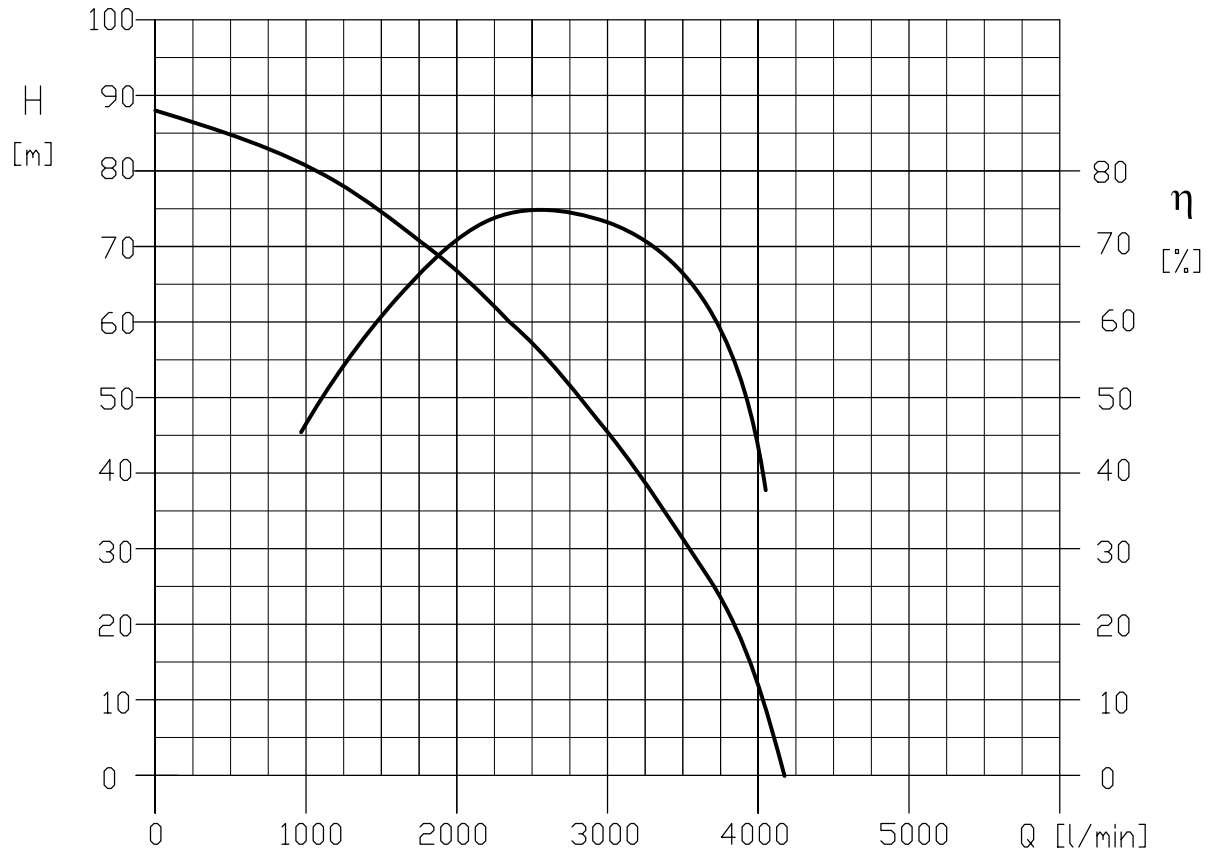

Rotation speed ≈ 2800 min⁻¹
Test standard: ISO 9906 – Annex A

SECTIONAL VIEW DUMPER 1X, 2X, 3X (except 3X 53.7,55.5,57.5), 4X, 6X, 7X

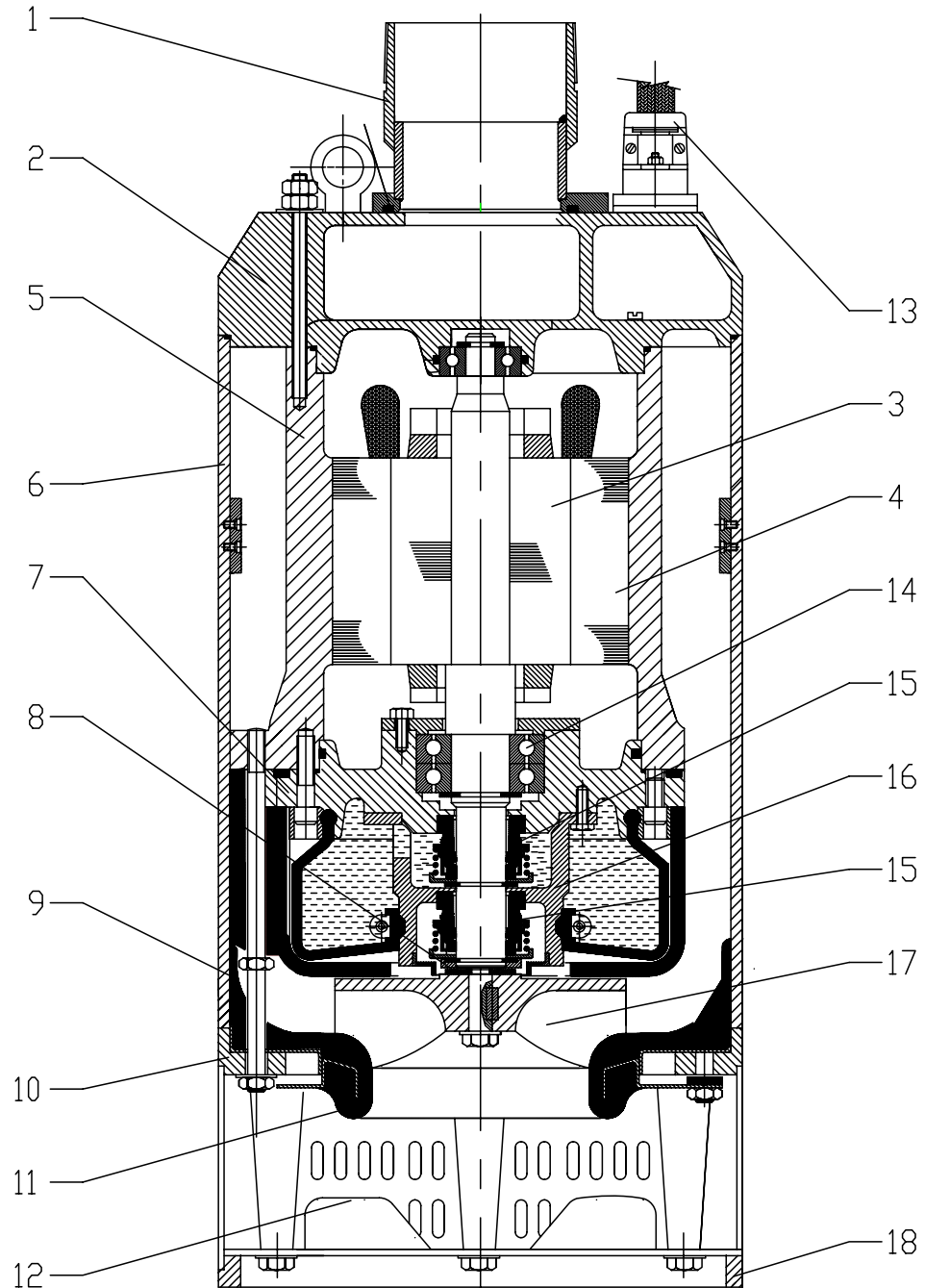

SECTIONAL VIEW TABLE DUMPER 1X, 2X, 3X (except 3X 53.7,55.5,57.5), 4X, 6X, 7X

N°	PART NAME	Q.TY
1	DISCHARGE OUTLET	1
2	TOP BRACKET	1
3	ROTOR COMPLETE	1
4	BARE STATOR	1
5	STATOR CASING	1
6	OUTER CASING	1
7	LOWER BEARING BRACKET	1
8	TRIMMING SPACER	AS REQD.
9	DIFFUSER RING	1
10	DIFFUSER HOLDER	1
11	DIFFUSER CENTRE	1
12	STRAINER	1
13	CABLE GLAND (Order with grip)	1
14	LOWER BEARING	1 SET
15	MECHANICAL SEAL	2
16	SEAL HOUSING	1
17	IMPELLER	1
18	BASE PLATE	1

SECTIONAL VIEW DUMPER 3X 53.7, 55.5, 57.5-S

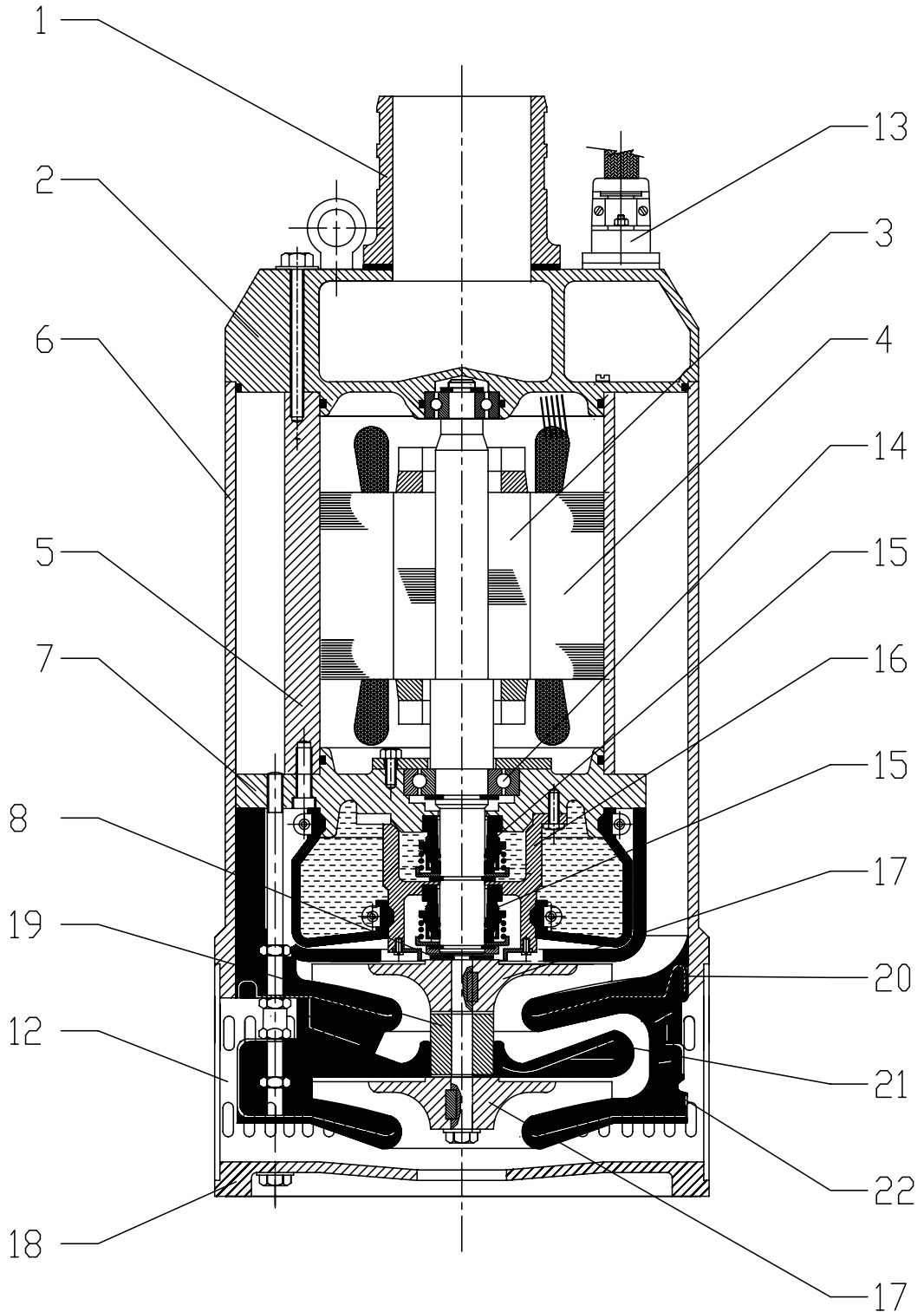

SECTIONAL VIEW TABLE DUMPER 3X 53.7, 55.5, 57.5-S

N°	PART NAME	Q.TY
1	OUTLET	1
2	TOP BRACKET	1
3	ROTOR COMPLETE	1
4	BARE STATOR	1
5	STATOR CASING	1
6	OUTER CASING	1
7	LOWER BEARING BRACKET	1
8	TRIMMING SPACER	AS REQD.
12	STRAINER	1
13	CABLE GLAND	1
14	LOWER BEARING	1
15	MECHANICAL SEAL	2
16	SEAL HOUSING	1
17	IMPELLER	2
18	BASE PLATE	1
19	SHAFT SLEEVE	1
20	DIFFUSOR(UPPER)	1
21	GUIDE PLATE	1
22	DIFFUSOR(LOWER)	1

SECTIONAL VIEW DUMPER 5X 58-S

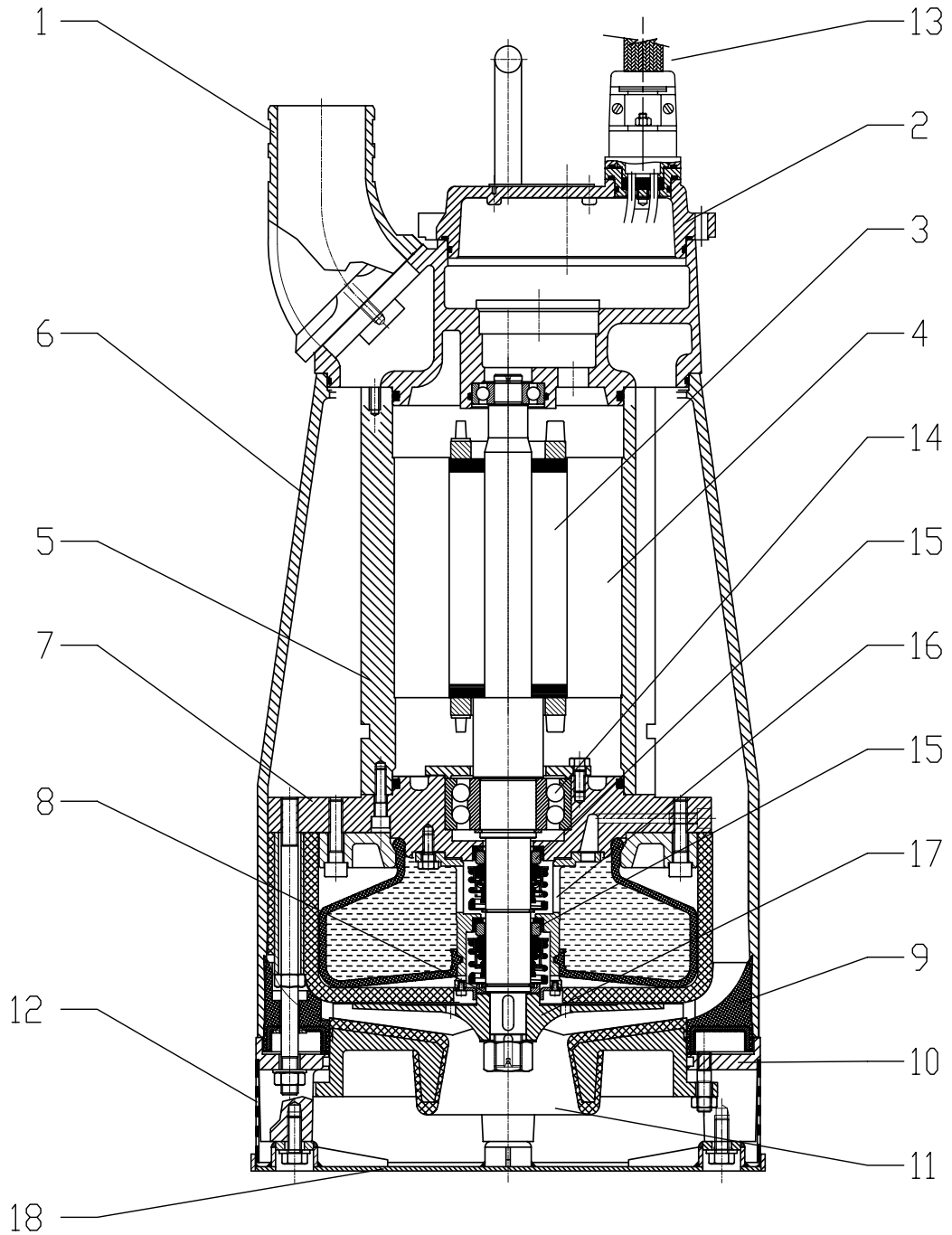

SECTIONAL VIEW TABLE DUMPER 5X 58-S

N°	PART NAME	Q.TY
1	DISCHARGE OUTLET (8'NPT)	1
2	TOP BRACKET	1
3	ROTOR COMPLETE	1
4	BARE STATOR	1
5	STATOR CASING	1
6	OUTER CASING	1
7	LOWER BEARING BRACKET	1
8	TRIMMING SPACER	1
9	DIFFUSER RING	1
10	DIFFUSER HOLDER	1
11	DIFFUSER CENTRE	1
12	STRAINER	1
13	CABLE GLAND (Order with grip)	1
14	LOWER BEARING	1 SET
15	MECHANICAL SEAL	2
16	SEAL HOUSING	1
17	IMPELLER	1
18	BASE PLATE	1

MECHANICAL SEAL

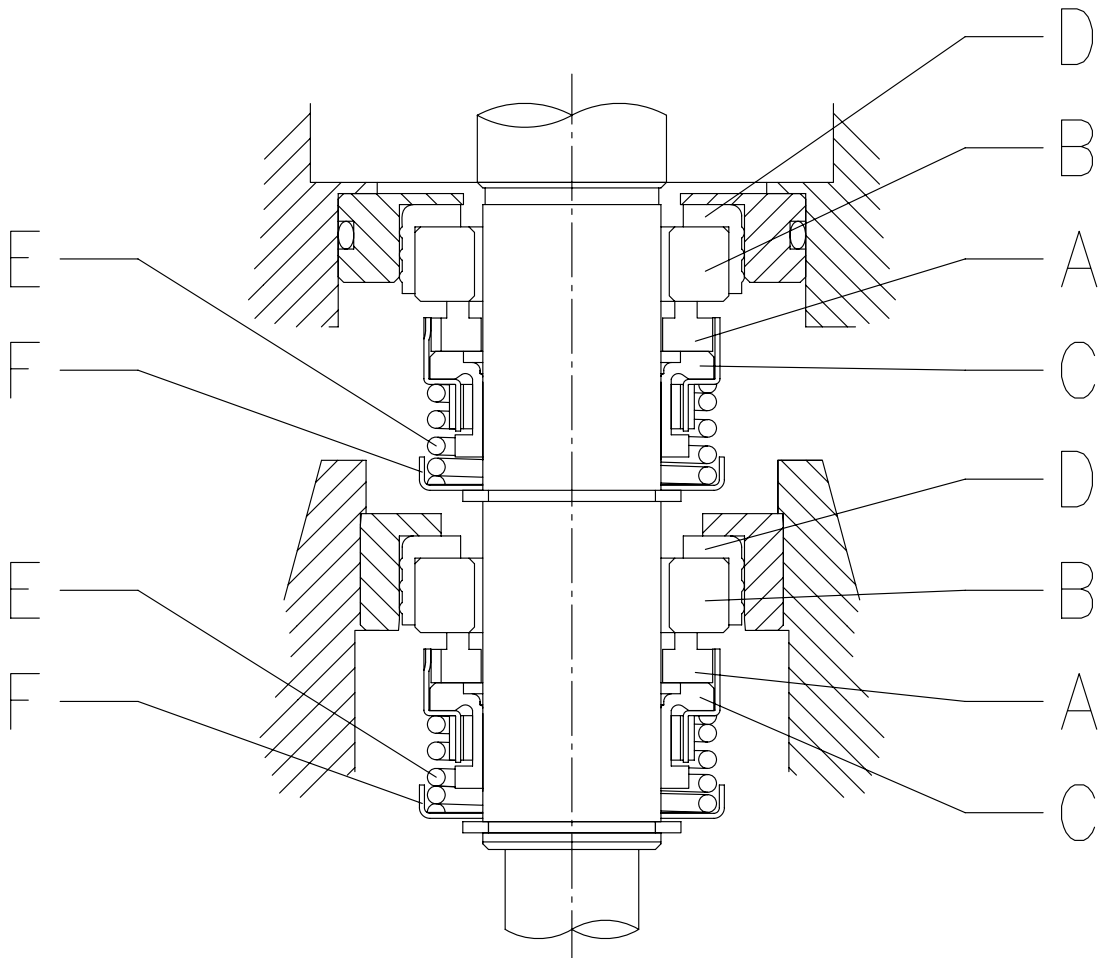

REF	PART NAME	MATERIAL
A	Rotary seal ring	Tungsten Carbide
B	Stationary seal ring	Tungsten Carbide
C	Gasket	NBR
D	Gasket	NBR
E	Self driving spring	Stainless steel
F	Frame	Stainless steel

BEARINGS

Pump	bearing	
	upper	lower
DUMPER 1X 51-S T	6203 ZZ	6303 ZZ
DUMPER 1X 51-S M-NC	6203 ZZ	6303 ZZ
DUMPER 1X 51-S M	6203 ZZ	6303 ZZ
DUMPER 1X 51.5-S T	6203 ZZ	6303 ZZ
DUMPER 2X 51.5-S T	6203 ZZ	6206 ZZ
DUMPER 2X 51.5-S M-NC	6203 ZZ	6206 ZZ
DUMPER 2X 52.2-S T	6203 ZZ	6206 ZZ
DUMPER 2X 52.2-S M-NC	6203 ZZ	6206 ZZ
DUMPER 2X 53-S T	6203 ZZ	6206 ZZ
DUMPER 3X 53.7-L T	6304 ZZ	6306 ZZ
DUMPER 3X 53.7-M T	6304 ZZ	6306 ZZ
DUMPER 3X 53.7-S T	6304 ZZ	6306 ZZ
DUMPER 3X 55.5-M T	6304 ZZ	6306 ZZ
DUMPER 3X 55.5-S T	6304 ZZ	6306 ZZ
DUMPER 3X 57.5-M T	6304 ZZ	6306 ZZ
DUMPER 3X 57.5-S T	6304 ZZ	6306 ZZ
DUMPER 4X 512-M T-SD	6305 ZZ	7308 BEC/BJ
DUMPER 4X 512-S T-SD	6305 ZZ	7308 BEC/BJ
DUMPER 5X 58-S	6304 ZZ	7308 BEC/BJ
DUMPER 6X 519-M T-SD	6305 ZZ	7310 BEC/BJ
DUMPER 6X 519-S T-SD	6305 ZZ	7310 BEC/BJ
DUMPER 6X 526-M T-SD	6306 ZZ	7310 BEC/BJ
DUMPER 6X 526-S T-SD	6306 ZZ	7310 BEC/BJ
DUMPER 6X 537-M T-SD	6306 ZZ	7310 BEC/BJ
DUMPER 7X 537-S T-SD	6306 ZZ	7311 BEC/BJ

PUMP

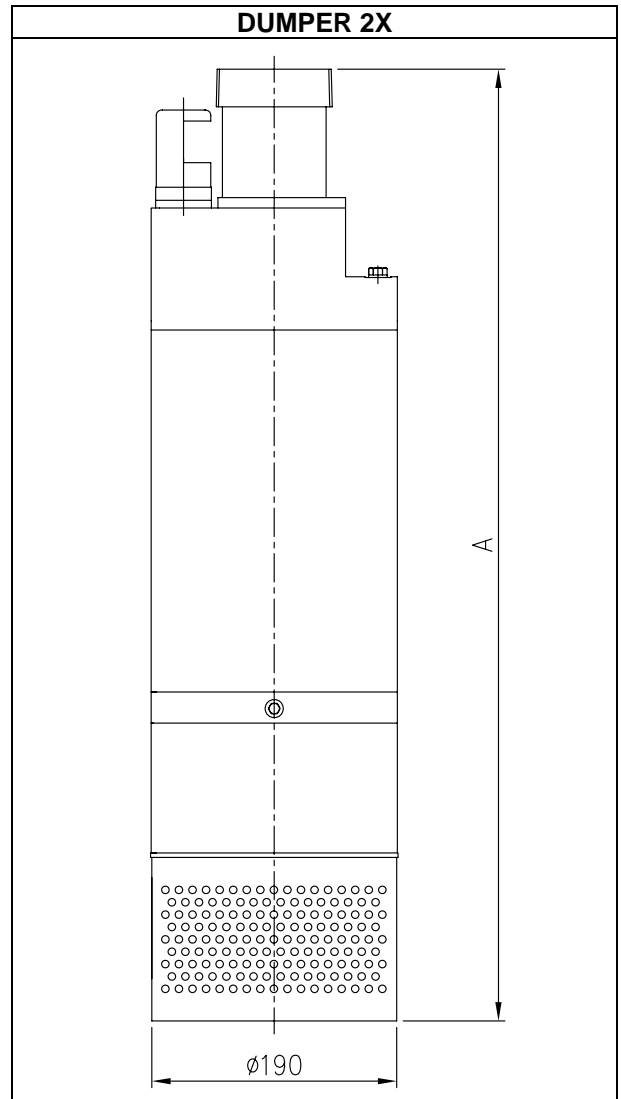
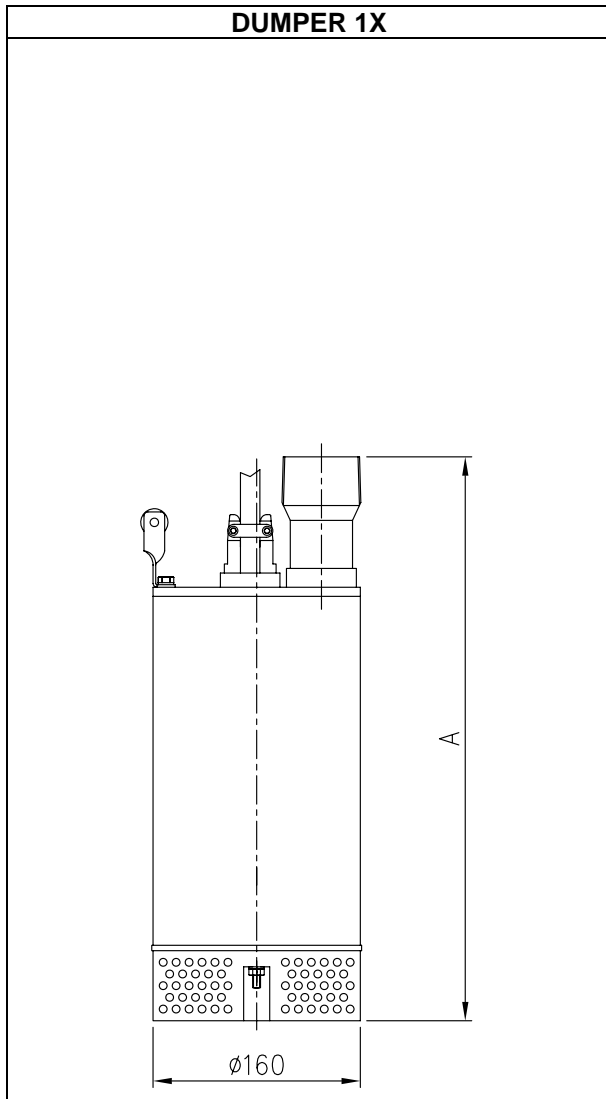

Model	Dimensions [mm]	Weight [kg]
DUMPER 1X 51-S M	504	26.1
DUMPER 1X 51-S T	434	21.1
DUMPER 1X 51-S M-NC	504	23.1
DUMPER 1X 51.5-S T	504	23.1

Model	Dimensions [mm]	Weight [kg]
DUMPER 2X 51.5-S T	640	33.1
DUMPER 2X 51.5-S M-NC	667	38.9
DUMPER 2X 52.2-S T	667	37.1
DUMPER 2X 52.2-S M-NC	725	44.9
DUMPER 2X 53-S T	700	42.1

PUMP DUMPER 3X, 4X, 6X, 7x SERIES

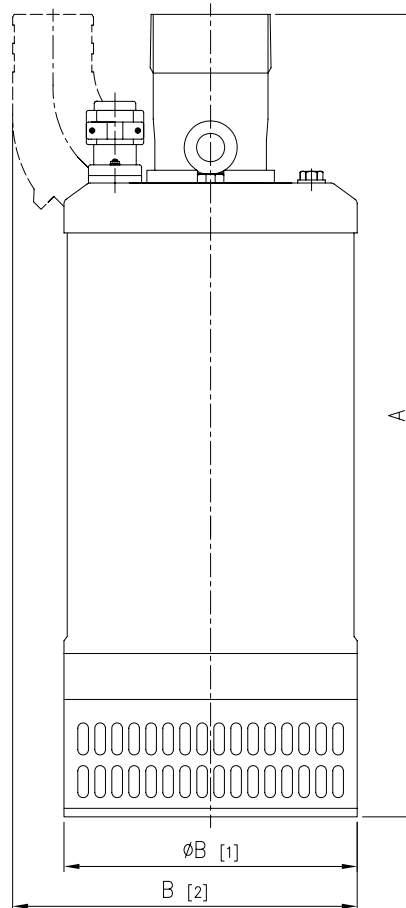

Model	Dimensions [mm]			Weight [kg]
	A	B (X = 0, 0L version) [1]	B (X = 1 version) [2]	
DUMPER 3X 53.7-L T	640	Ø276	330	48.9
DUMPER 3X 53.7-M T	640	Ø276	330	46.9
DUMPER 3X 53.7-S T	640	Ø276	330	59.9
DUMPER 3X 55.5-M T	725	Ø276	330	61.9
DUMPER 3X 55.5-S T	725	Ø276	330	66.9
DUMPER 3X 57.5-M T	750	Ø276	330	71.9
DUMPER 3X 57.5-S T	750	Ø276	-	72.9
DUMPER 4X 512-M T	845	Ø360	405	131.9
DUMPER 4X 512-S T	845	Ø360	405	146.9
DUMPER 6X 519-M T	915	Ø400	455	194.2
DUMPER 6X 519-S T	915	Ø400	455	204.2
DUMPER 6X 526-M T	1029	Ø400	508	238.9
DUMPER 6X 526-S T	1029	Ø400	508	248.9
DUMPER 6X 537-M T	1055	Ø400	-	257.4
DUMPER 7X 537-S T	1055	Ø440	-	397.4

PACKING

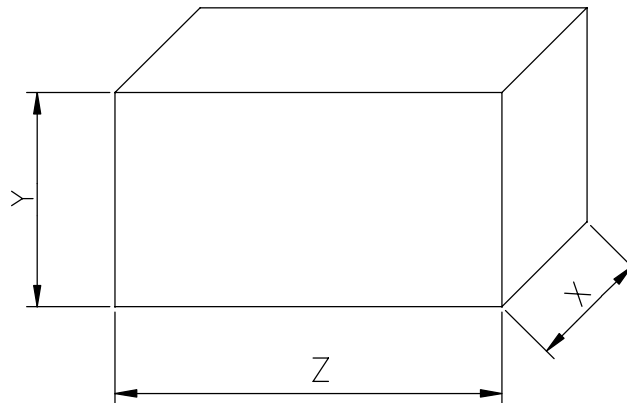

Model	Dimensions [mm]			WEIGHT [kg]	Packaging Type
	X	Y	Z		
DUMPER 1X 51-S T	190	190	508	23.1	CARTON BOX
DUMPER 1X 51-S M-NC				25.1	
DUMPER 1X 51-S M	228	228	813	28.1	
DUMPER 1X 51.5-S T	190	190	508	28.1	
DUMPER 2X 51.5-S T	228	228	813	35.1	
DUMPER 2X 51.5-S M-NC				40.9	
DUMPER 2X 52.2-S T				39.1	
DUMPER 2X 52.2-S M-NC				46.9	
DUMPER 2X 53-S T				44.1	
DUMPER 3X 53.7-L T	330	330	800	50.9	
DUMPER 3X 53.7-M T				48.9	
DUMPER 3X 53.7-S T				61.9	
DUMPER 3X 55.5-M T				63.9	
DUMPER 3X 55.5-S T				68.9	
DUMPER 3X 57.5-M T				72.9	
DUMPER 3X 57.5-S T				74.9	
DUMPER 4X 512-M T	457	915	406	164.9	WOODEN BOX
DUMPER 4X 512-S T				179.9	
DUMPER 5X 58-S	450	450	850	100	
DUMPER 6X 519-M T	559	1067	483	236.2	
DUMPER 6X 519-S T				246.2	
DUMPER 6X 526-M T	533	1118	483	288.9	
DUMPER 6X 526-S T				298.9	
DUMPER 6X 537-M T	483	1143	584	298.9	
DUMPER 7X 537-S T				447.4	

Model		P ₂		Locked rotor current [A]				Input in [kW]		Full load current [A]			
Single Phase	Three Phase	kW	HP	Single Phase 230 V	Three Phase 376 V 400 V 424 V			Single Phase	Three Phase	Single Phase 230 V	Three Phase 376 V 400 V 424 V		
DUMPER 1X 51-S M - M-NC	DUMPER 1X 51-S T	1	1.3	60	14.7	13.8	13.0	1.2	1.2	10.0	2.5	2.3	2.2
-	DUMPER 1X 51.5-S T	1.5	2	-	24.9	23.4	22.0	-	1.9	-	4.2	3.9	3.7
DUMPER 2X 51.5-S M-NC	DUMPER 2X 51.5-S T	1.5	2	114	28.1	26.4	24.9	1.9	1.9	19.0	4.7	4.4	4.2
DUMPER 2X 52.2-S M-NC	DUMPER 2X 52.2-S T	2.2	3	144	35.1	33.0	31.1	2.8	2.8	24.0	5.9	5.5	5.2
-	DUMPER 2X 53-S T	3	4	-	51.1	48.0	45.3	-	3.8	-	8.5	8.0	7.6
-	DUMPER 3X 53.7-L T	3.7	5	-	51.7	48.6	45.9	-	4.2	-	8.6	8.1	7.6
-	DUMPER 3X 53.7-M T	3.7	5	-	51.7	48.6	45.9	-	4.2	-	8.6	8.1	7.6
-	DUMPER 3X 53.7-S T	3.7	5	-	51.7	48.6	45.9	-	4.2	-	8.6	8.1	7.6
-	DUMPER 3X 55.5-M T	5.5	7.5	-	79.8	75.0	70.8	-	6.4	-	13.2	12.5	11.8
-	DUMPER 3X 55.5-S T	5.5	7.5	-	79.8	75.0	70.8	-	7.0	-	13.2	12.5	11.8
-	DUMPER 3X 57.5-M T	7.5	10	-	102.1	96.0	90.6	-	8.4	-	17.0	16.0	15.1
-	DUMPER 3X 57.5-S T	7.5	10	-	102.1	96.0	90.6	-	8.4	-	17.0	16.0	15.1
-	DUMPER 4X 512-M T	12	16	-	108.5	102.0	96.3	-	13.2	-	18.1	17.0	16.0
-	DUMPER 4X 512-S T	12	16	-	108.5	102.0	96.3	-	13.2	-	18.1	17.0	16.0
-	DUMPER 5X 58-S	8	10.75	-	119	112.0	105	-	9.0	-	18.0	17.0	16
-	DUMPER 6X 519-M T	19	25	-	248.9	234.0	220.8	-	21.0	-	41.5	39.0	36.8
-	DUMPER 6X 519-S T	19	25	-	248.9	234.0	220.8	-	21.0	-	41.5	39.0	36.8
-	DUMPER 6X 526-M T	26	35	-	325.5	306.0	288.7	-	27.0	-	54.3	51.0	48.1
-	DUMPER 6X 526-S T	26	35	-	325.5	306.0	288.7	-	27.0	-	54.3	51.0	48.1
-	DUMPER 6X 537-M T	37	50	-	395.8	372.0	351.0	-	39.0	-	66.0	62.0	58.5
-	DUMPER 7X 537-S T	37	50	-	395.8	372.0	352.0	-	39.0	-	66.0	62.0	58.5